

AQA(B) AS Module I**Contents**

Specification		2
Biological Molecules	Chemical bonds	4
	Carbohydrates	5
	Lipids	7
	Proteins	9
	Biochemical Tests	15
	Enzymes	16
Cells	Eukaryotic Cells	22
	Prokaryotic Cells	27
	Cell Fractionation	29
	Microscopy	30
	The Cell Membrane	34
	Movement across Cell Membranes	36
	Exchange	42
Physiology and Disease	Disease	43
	Lifestyle and Disease	45
	The Digestive System	47
	Cholera	51
	The Gas Exchange System	53
	Lung Diseases	57
	The Circulatory System	61
	Heart Disease	65
	The Immune System	67
	Immunisation	76
Monoclonal Antibodies	77	

These notes may be used freely by A level biology students and teachers, and they may be copied and edited.

Please do not use these materials for commercial purposes.
I would be interested to hear of any comments and corrections.

Neil C Millar (nmillar@ntlworld.co.uk)
Head of Biology, Heckmondwike Grammar School
High Street, Heckmondwike, WF16 0AH
Sept 2008

Module I Specification

Biochemistry

Biological Molecules

Biological molecules such as carbohydrates and proteins are often polymers and are based on a small number of chemical elements.

- Proteins have a variety of functions within all living organisms. The general structure of an amino acid. Condensation and the formation of peptide bonds linking together amino acids to form polypeptides. The relationship between primary, secondary, tertiary and quaternary structure, and protein function.
- Monosaccharides are the basic molecular units (monomers) of which carbohydrates are composed. The structure of α -glucose and the linking of α -glucose by glycosidic bonds formed by condensation to form maltose and starch. Sucrose is a disaccharide formed by condensation of glucose and fructose. Lactose is a disaccharide formed by condensation of glucose and galactose.
- Glycerol and fatty acids combine by condensation to produce triglycerides. The R-group of a fatty acid may be saturated or unsaturated. In phospholipids, one of the fatty acids of a triglyceride is substituted by a phosphate group.

Biochemical Tests

Iodine/potassium iodide solution for starch. Benedict's reagent for reducing sugars and non-reducing sugars. The biuret test for proteins. The emulsion test for lipids.

Enzymes

Enzymes as catalysts lowering activation energy through the formation of enzyme-substrate complexes. The lock and key and induced fit models of enzyme action. Use the lock and key model to explain the properties of enzymes. Recognise its limitations and be able to explain why the induced fit model provides a better explanation of specific enzyme properties. The properties of enzymes relating to their tertiary structure.

Description and explanation of the effects of temperature, competitive and non-competitive inhibitors, pH and substrate concentration. Investigate the effect of a specific variable on the rate of reaction of an enzyme-controlled reaction.

Cell Biology

Cells

The appearance, ultrastructure and function of plasma membrane; microvilli; nucleus; mitochondria; lysosomes; ribosomes; endoplasmic reticulum and Golgi apparatus. Apply their knowledge of these features in explaining adaptations of other eukaryotic cells.

The structure of prokaryotic cells to include cell wall, plasma membrane, capsule, circular DNA, flagella and plasmid.

Plasma Membranes

The arrangement of phospholipids, proteins and carbohydrates in the fluid-mosaic model of membrane structure. Use the fluid mosaic model to explain appropriate properties of plasma membranes.

- The role of carrier proteins and protein channels in facilitated diffusion.
- Osmosis is a special case of diffusion in which water moves from a solution of higher water potential to a solution of lower water potential through a partially permeable membrane. Investigate the effect of solute concentration on the rate of uptake of water by plant tissue.
- The role of carrier proteins and the transfer of energy in the active transport of substances against a concentration gradient.

Microscopes and Cell Fractionation

The principles and limitations of transmission and scanning electron microscopes. The difference between magnification and resolution. Principles of cell fractionation and ultracentrifugation as used to separate cell components.

Exchange

Diffusion is the passive movement of substances down a concentration gradient. Surface area, difference in concentration and the thickness of the exchange surface affect the rate of diffusion.

Disease

Disease may be caused by infectious pathogens or may reflect the effects of lifestyle.

- Pathogens include bacteria, viruses and fungi. Disease can result from pathogenic microorganisms penetrating any of an organism's interfaces with the environment. These interfaces include the digestive and gas-exchange systems. Pathogens cause disease by damaging the cells of the host and by producing toxins.
- Lifestyle can affect human health. Specific risk factors are associated with cancer and coronary heart disease. Changes in lifestyle may also be associated with a reduced risk of contracting these conditions. Analyse and interpret data associated with specific risk factors and the incidence of disease. Recognise correlations and causal relationships.

Physiology and Disease

Digestive System

The gross structure of the human digestive system limited to oesophagus, stomach, small and large intestines and rectum. The glands associated with this sys-

tem limited to the salivary glands and the pancreas. The structure of an epithelial cell from the small intestine as seen with an optical microscope.

Digestion is the process in which large molecules are hydrolysed by enzymes to produce smaller molecules that can be absorbed and assimilated. The role of salivary and pancreatic amylases in the digestion of starch and of maltase located in the intestinal epithelium. Digestion of disaccharides by sucrase and lactase. Absorption of the products of carbohydrate digestion. The roles of diffusion, active transport and co-transport involving sodium ions. The role of microvilli in increasing surface area. Lactose intolerance.

Cholera and Diarrhoea

The cholera bacterium as an example of a prokaryotic organism. Cholera bacteria produce toxins that increase secretion of chloride ions into the lumen of the intestine. This results in severe diarrhoea. The use of oral rehydration solutions (ORS) in the treatment of diarrhoeal diseases. Discuss the applications and implications of science in developing improved oral rehydration solutions; and ethical issues associated with trialling improved oral rehydration solutions on humans.

Gas Exchange System

The gross structure of the human gas exchange system limited to the alveoli, bronchioles, bronchi, trachea and lungs. The essential features of the alveolar epithelium as a surface over which gas exchange takes place. The exchange of gases in the lungs. Pulmonary ventilation as the product of tidal volume and ventilation rate. The mechanism of breathing.

Lung Diseases

The course of infection, symptoms and transmission of pulmonary tuberculosis. The effects of fibrosis, asthma and emphysema on lung function. Explain the symptoms of diseases and conditions affecting the lungs in terms of gas exchange and respiration. Interpret data relating to the effects of pollution and smoking on the incidence of lung disease. Analyse and interpret data associated with specific risk factors and the incidence of lung disease.

Circulatory System

Heart structure and function. The gross structure of the human heart and its associated blood vessels in relation to function. Myogenic stimulation of the heart

and transmission of a subsequent wave of electrical activity. Roles of the sinoatrial node (SAN), atrioventricular node (AVN) and bundle of His. Pressure and volume changes and associated valve movements during the cardiac cycle. Candidates should be able to analyse and interpret data relating to pressure and volume changes during the cardiac cycle. Cardiac output as the product of heart rate and stroke volume. Investigate the effect of a specific variable on human heart rate or pulse rate.

Coronary Heart Disease

Atheroma as the presence of fatty material within the walls of arteries. The link between atheroma and the increased risk of aneurysm and thrombosis. Myocardial infarction and its cause in terms of an interruption to the blood flow to heart muscle. Risk factors associated with coronary heart disease: diet, blood cholesterol, cigarette smoking and high blood pressure. Describe and explain data relating to the relationship between specific risk factors and the incidence of coronary heart disease.

Immune System

Mammalian blood possesses a number of defensive functions. Phagocytosis and the role of lysosomes and lysosomal enzymes in the subsequent destruction of ingested pathogens.

Definition of antigen and antibody. Antibody structure and the formation of an antigen-antibody complex. The essential difference between humoral and cellular responses as shown by B cells and T cells. The role of plasma cells and memory cells in producing a secondary response. The effects of antigenic variability in the influenza virus and other pathogens on immunity.

The use of vaccines to provide protection for individuals and populations against disease. The use of monoclonal antibodies in enabling the targeting of specific substances and cells.

Evaluate methodology, evidence and data relating to the use of vaccines and monoclonal antibodies. Discuss ethical issues associated with the use of vaccines and monoclonal antibodies. Explain the role of the scientific community in validating new knowledge about vaccines and monoclonal antibodies thus ensuring integrity. Discuss the ways in which society uses scientific knowledge relating to vaccines and monoclonal antibodies to inform decision-making.

Biological Molecules

Life on Earth evolved in the water, and all life still depends on water. At least 80% of the mass of living organisms is water, and almost all the chemical reactions of life take place in aqueous solution. The other chemicals that make up living things are mostly organic macromolecules belonging to the four groups carbohydrates, lipids, proteins, or nucleic acids. These macromolecules are polymers, made up from specific monomers as shown in the table below. Between them these four groups make up 93% of the dry mass of living organisms, the remaining 7% comprising small organic molecules (like vitamins) and inorganic ions.

Group name	Elements	Monomers	Polymers	% dry mass of a cell
Carbohydrates	CHO	monosaccharides	polysaccharides	15
Lipids	CHOP	fatty acids + glycerol*	triglycerides	10
Proteins	CHONS	amino acids	polypeptides	50
Nucleic acids	CHONP	nucleotides	polynucleotides	18

* These are not monomers, but rather the components of triglycerides.

The first part of this unit is about each of these groups. We'll look at each of these groups in detail, except nucleic acids (DNA and RNA), which are studied in unit 2.

Chemical Bonds

In biochemistry there are two important types of chemical bond: the covalent bond and the hydrogen bond.

Covalent bonds are strong. They hold together all the organic molecules in living organisms. Because they are strong, covalent bonds cannot be broken or made at the temperatures found in living cells. So in biology covalent bonds are always made or broken by the action of enzymes. Covalent bonds are represented by solid lines in chemical structures.

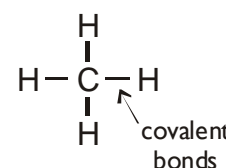

Hydrogen bonds are much weaker. They are formed between an atom (usually hydrogen) with a slight positive charge (denoted δ^+) and an atom (usually oxygen or nitrogen) with a slight negative charge (denoted δ^-). Because hydrogen bonds are weak they can be easily made and broken inside cells without needing enzymes. Hydrogen bonds are represented by dotted lines in chemical structures.

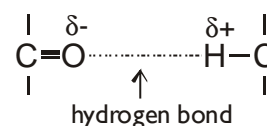

Carbohydrates

Carbohydrates contain only the elements carbon, hydrogen and oxygen. The group includes monomers, dimers and polymers, as shown in this diagram:

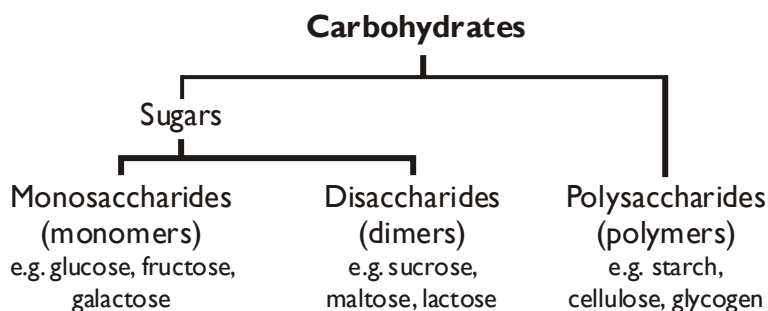

Monosaccharides

These all have the formula $(\text{CH}_2\text{O})_n$, where n can be 3-7. The most common and important monosaccharide is glucose, which is a six-carbon or hexose sugar, so has the formula $\text{C}_6\text{H}_{12}\text{O}_6$. Its structure is:



Glucose forms a six-sided ring, although in three-dimensions it forms a structure that looks a bit like a chair. In animals glucose is the main transport sugar in the blood, and its concentration in the blood is carefully controlled. There are many isomers of glucose, with the same chemical formula ($\text{C}_6\text{H}_{12}\text{O}_6$), but different structural formulae. These isomers include galactose and fructose:



Common five-carbon, or pentose sugars (where $n = 5$, $\text{C}_5\text{H}_{10}\text{O}_5$) include ribose and deoxyribose (found in nucleic acids and ATP, see unit 2) and ribulose (which occurs in photosynthesis). Three-carbon, or triose sugars (where $n = 3$, $\text{C}_3\text{H}_6\text{O}_3$) are also found in respiration and photosynthesis (see unit 4).

Disaccharides

Disaccharides are formed when two monosaccharides are joined together by a glycosidic bond (C–O–C). The reaction involves the formation of a molecule of water (H₂O):

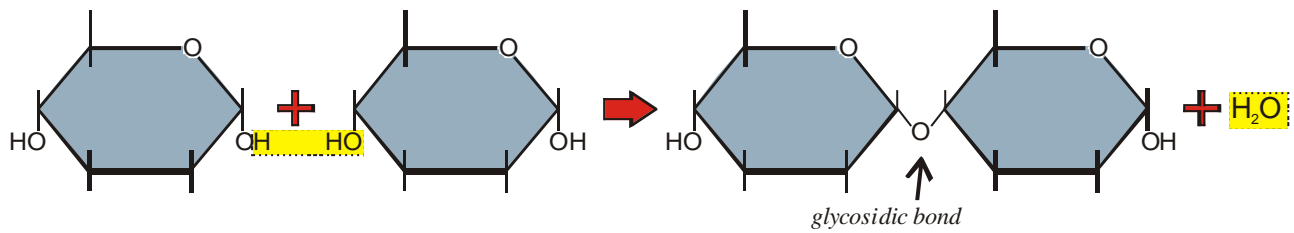

This shows two glucose molecules joining together to form the disaccharide maltose. This kind of reaction, where two molecules combine into one bigger molecule, is called a condensation reaction. The reverse process, where a large molecule is broken into smaller ones by reacting with water, is called a hydrolysis reaction.

In general:

- polymerisation reactions are condensations
- breakdown reactions are hydrolyses

There are three common disaccharides:

Maltose (or malt sugar) is glucose–glucose. It is formed on digestion of starch by amylase, because this enzyme breaks starch down into two-glucose units. Brewing beer starts with malt, which is a maltose solution made from germinated barley.

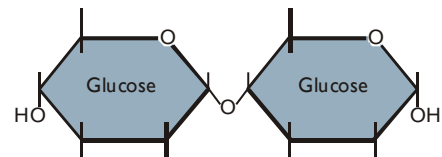

Sucrose (or cane sugar) is glucose–fructose. It is common in plants because it is less reactive than glucose, and it is their main transport sugar. It is the common table sugar that you put in your tea.

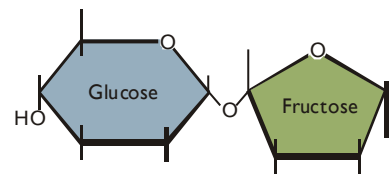

Lactose (or milk sugar) is galactose–glucose. It is found only in mammalian milk, and is the main source of energy for infant mammals.

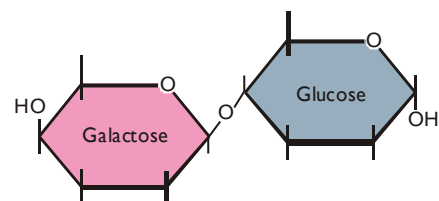

Starch

Starch is a polysaccharide found in plants. It is a long chain of many glucose monomers joined together by glycosidic bonds:



Lipids

Lipids are a mixed group of hydrophobic compounds composed of the elements carbon, hydrogen, oxygen and sometime phosphorus (CHOP). The most common lipids are triglycerides and phospholipids.

Triglycerides

Triglycerides, or triacylglycerols, are made of glycerol and fatty acids.

Glycerol is a small, 3-carbon molecule with three alcohol (OH) groups.

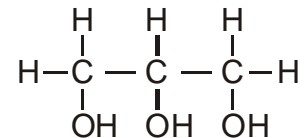

Fatty acids are long molecules made of a non-polar hydrocarbon chain with a polar carboxyl acid group at one end. The hydrocarbon chain can be from 14 to 22 CH₂ units long. Because the length of the hydrocarbon chain can vary it is sometimes called an R group, so the formula of a fatty acid can be written as R-COOH.

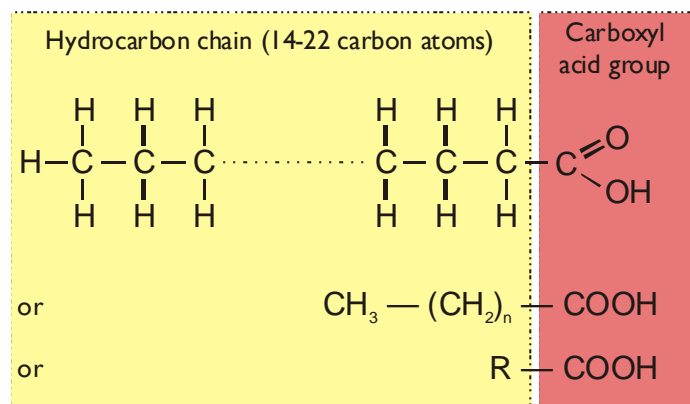

One molecule of glycerol joins together with three fatty acid molecules by ester bonds to form a triglyceride molecule, in another condensation polymerisation reaction:

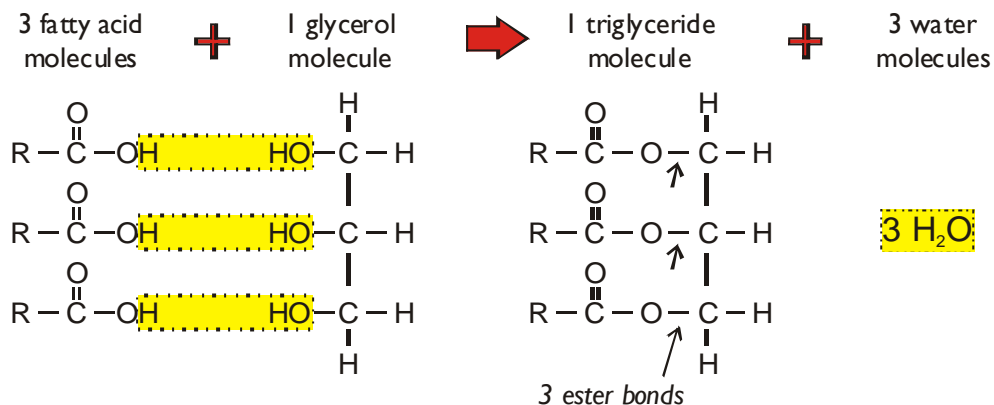

Triglycerides are commonly known as fats or oils, and are insoluble in water. They are used for storage, insulation and protection in fatty tissue (or adipose tissue) found under the skin (subcutaneous) or surrounding organs. When oxidised triglycerides yield more energy per unit mass than other compounds so are good for energy storage. However, triglycerides can't be mobilised quickly since they are so insoluble, so are no good for quick energy requirements. Tissues that need energy quickly (like muscles) instead store carbohydrates like glycogen.

- If the fatty acid chains in a triglyceride have no C=C double bonds, then they are called saturated fatty acids (i.e. saturated with hydrogen). Triglycerides with saturated fatty acids have a high melting point and tend to be found in warm-blooded animals. At room temperature they are solids (fats), e.g. butter, lard.
- If the fatty acid chains in a triglyceride do have C=C double bonds they are called unsaturated fatty acids (i.e. unsaturated with hydrogen). Fatty acids with more than one double bond are called poly-unsaturated fatty acids (PUFAs). Triglycerides with unsaturated fatty acids have a low melting point and tend to be found in cold-blooded animals and plants. At room temperature they are liquids (oils), e.g. fish oil, vegetable oils.

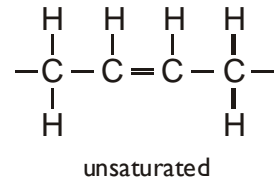
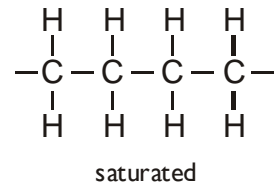

Phospholipids

Phospholipids have a similar structure to triglycerides, but with a phosphate group in place of one fatty acid chain. There may also be other groups attached to the phosphate. Phospholipids have a polar hydrophilic "head" (the negatively-charged phosphate group) and two non-polar hydrophobic "tails" (the fatty acid chains).

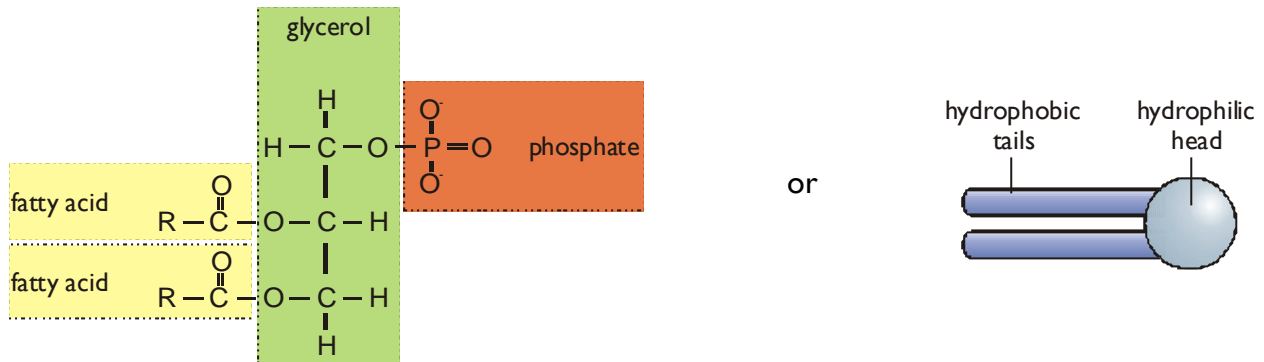

This mixture of properties is fundamental to biology, for phospholipids are the main components of cell membranes. When mixed with water, phospholipids form droplet spheres with a double-layered phospholipid bilayer. The hydrophilic heads facing the water and the hydrophobic tails facing each other. This traps a compartment of water in the middle separated from the external water by the hydrophobic sphere. This naturally-occurring structure is called a liposome, and is similar to a membrane surrounding a cell.

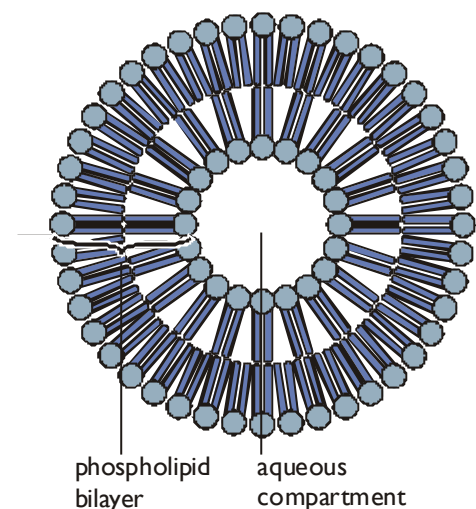

Proteins

Proteins are the most complex and most diverse group of biological compounds. They have an astonishing range of different functions, as this list shows.

structure	e.g. collagen (bone, cartilage, tendon), keratin (hair), actin (muscle)
enzymes	e.g. amylase, pepsin, catalase, etc (>10,000 others)
transport	e.g. haemoglobin (oxygen), transferrin (iron)
pumps	e.g. Na ⁺ K ⁺ pump in cell membranes
motors	e.g. myosin (muscle), kinesin (cilia)
hormones	e.g. insulin, glucagon
receptors	e.g. rhodopsin (light receptor in retina)
antibodies	e.g. immunoglobulins
storage	e.g. albumins in eggs and blood, caesin in milk
blood clotting	e.g. thrombin, fibrin
lubrication	e.g. glycoproteins in synovial fluid
toxins	e.g. diphtheria toxin
antifreeze	e.g. glycoproteins in arctic flea
and many more!	

Amino Acids

Proteins are made of amino acids. Amino acids are made of the five elements CHONS. Amino acids are so-called because they contain both an amino group and an acid group. The general structure of an amino acid molecule is shown on the right. There is a central carbon atom (called the "alpha carbon", C_α), with four different chemical groups attached to it:

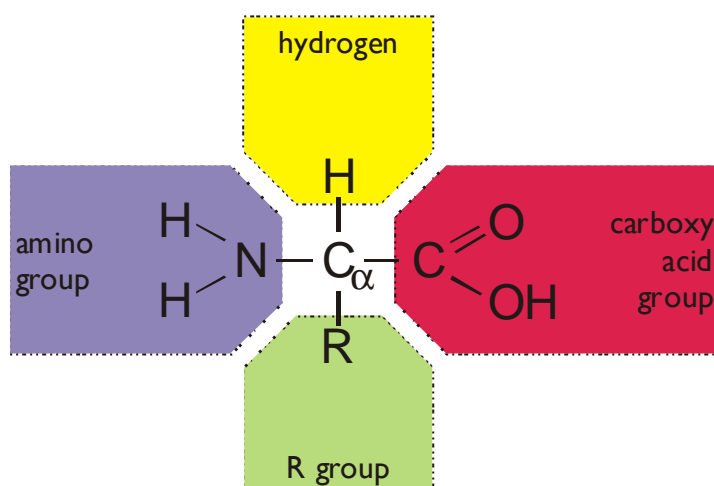

1. a hydrogen atom
2. a basic amino group (NH₂ or NH₃⁺)
3. an acidic carboxyl group (COOH or COO⁻)
4. a variable "R" group (or side chain)

There are 20 different R groups, and so 20 different amino acids. Since each R group is slightly different, each amino acid has different properties, and this in turn means that proteins can have a wide range of properties. The table on the next page shows the 20 different R groups, grouped by property, which gives an idea of the range of properties. You do not need to learn these, but it is interesting to see the different structures, and you should be familiar with the amino acid names. You may already have heard of some, such as the food additive monosodium glutamate, which is simply the sodium salt of the amino acid glutamate. There are 3-letter and 1-letter abbreviations for each amino acid.

Polypeptides

Amino acids are joined together by peptide bonds. The reaction involves the formation of a molecule of water in another condensation polymerisation reaction:

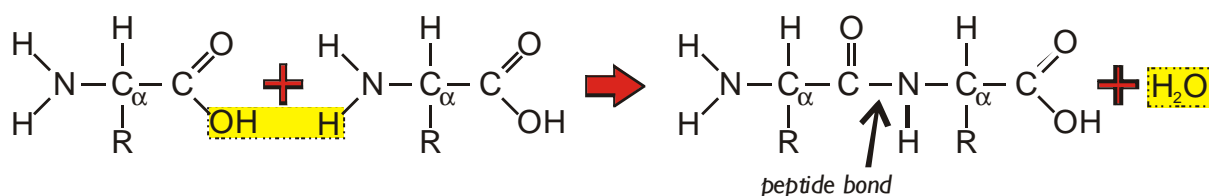

When two amino acids join together a dipeptide is formed. Three amino acids form a tripeptide. Many amino acids form a polypeptide. e.g.:



In a polypeptide there is always one end with a free amino (NH_2) group, called the N-terminus, and one end with a free carboxyl (COOH) group, called the C-terminus.

In a protein the polypeptide chain may be many hundreds of amino acids long. Amino acid polymerisation to form polypeptides is part of protein synthesis. It takes place in ribosomes, and is special because it requires an RNA template. The sequence of amino acids in a polypeptide chain is determined by the sequence of the bases in DNA. Protein synthesis is studied in detail in unit 5.

The Twenty Amino Acid R-Groups			
Simple R groups		Basic R groups	
Glycine Gly G	- H	Lysine Lys K	- CH ₂ -CH ₂ -CH ₂ -CH ₂ -NH ₃ ⁺
Alanine Ala A	- CH ₃	Arginine Arg R	- CH ₂ -CH ₂ -CH ₂ -NH-C(=NH ₂) ₂ ⁺
Valine Val V	- CH(CH ₃) ₂	Histidine His H	- CH ₂ -C(=CH)N=CH-NH
Leucine Leu L	- CH ₂ -CH(CH ₃) ₂	Asparagine Asn N	- CH ₂ -C(=O)NH ₂
Isoleucine Ile I	- CH(CH ₃)-CH ₂ -CH ₃	Glutamine Gln Q	- CH ₂ -CH ₂ -C(=O)NH ₂
Hydroxyl R groups		Acidic R groups	
Serine Ser S	- CH ₂ -OH	Aspartate Asp D	- CH ₂ -C(=O)OH
Threonine Thr T	- CH(CH ₃)-OH	Glutamate Glu E	- CH ₂ -CH ₂ -C(=O)OH
Sulphur R groups		Ringed R groups	
Cysteine Cys C	- CH ₂ -SH	Phenylalanine Phe F	- CH ₂ -C ₆ H ₅
Methionine Met M	- CH ₂ -CH ₂ -S-CH ₃	Tyrosine Tyr Y	- CH ₂ -C ₆ H ₄ -OH
Proline Pro P	- C _α (NH)-CH ₂ -CH ₂ -CH ₂	Tryptophan Trp W	- CH ₂ -CH(CH ₂ -C ₆ H ₄ -NH)-CH ₂

Protein Structure

Polypeptides are just strings of amino acids, but they fold up and combine to form the complex and well-defined three-dimensional structure of working proteins. To help to understand protein structure, it is broken down into four levels:

1. Primary Structure

This is just the sequence of amino acids in the polypeptide chain, so is not really a structure at all. However, the primary structure does determine the rest of the protein structure.

2. Secondary Structure

This is the most basic level of protein folding, and consists of a few basic motifs that are found in almost all proteins. The secondary structure is held together by hydrogen bonds between the carboxyl groups and the amino groups in the polypeptide backbone. The two most common secondary structure motifs are the α -helix and the β -sheet.

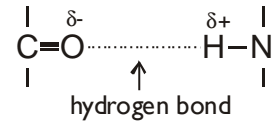

The α -helix. The polypeptide chain is wound round to form a helix. It is held together by hydrogen bonds running parallel with the long helical axis. There are so many hydrogen bonds that this is a very stable and strong structure. Do not confuse the α -helix of proteins with the famous double helix of DNA – helices are common structures throughout biology.

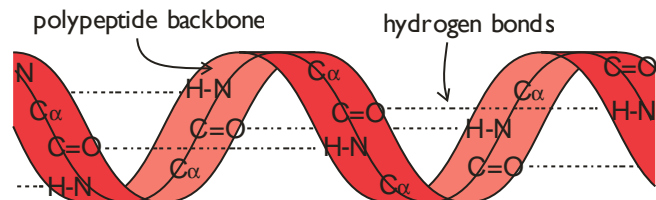

The β -sheet. The polypeptide chain zig-zags back and forward forming a sheet of anti-parallel strands. Once again it is held together by hydrogen bonds.

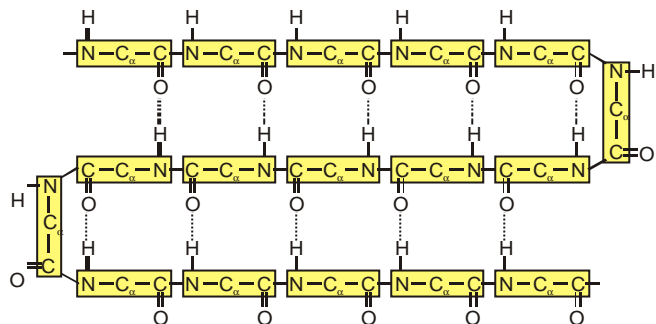

3. Tertiary Structure

This is the compact globular structure formed by the folding up of a whole polypeptide chain. Every protein has a unique tertiary structure, which is responsible for its properties and function. For example the shape of the active site in an enzyme is due to its tertiary structure. The tertiary structure is held together by bonds between the R groups of the amino acids in the protein, and so depends on what the sequence of amino acids is.

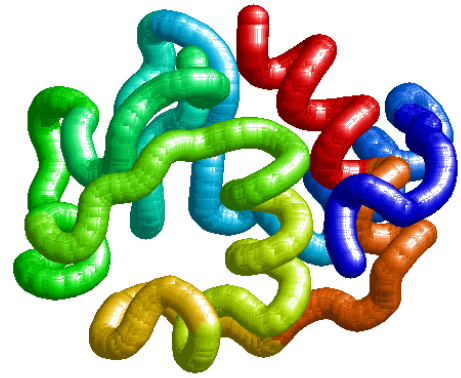

These bonds include weak hydrogen bonds and sulphur bridges - covalent S-S bonds between two cysteine amino acids, which are much stronger.

So the secondary structure is due to backbone interactions and is thus largely independent of primary sequence, while tertiary structure is due to side chain interactions and thus depends on the amino acid sequence.

4. Quaternary Structure

Almost all working proteins are actually composed of more than one polypeptide chain, and the arrangement of the different chains is called the quaternary structure. There are a huge variety of quaternary structures e.g.:

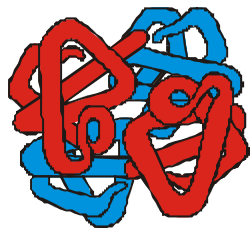

Haemoglobin consists of four chains arranged in a tetrahedral (pyramid) structure.

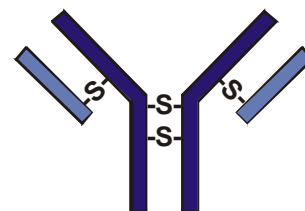

Antibodies comprise four chains arranged in a Y-shape.

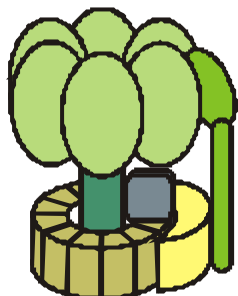

The enzyme ATP synthase is composed of 22 chains forming a rotating motor.



Collagen consists of three chains in a triple helix structure.



Actin consists of hundreds of globular chains arranged in a long double helix.

These four structures are not real stages in the formation of a protein, but are simply a convenient classification that scientists invented to help them to understand proteins. In fact proteins fold into all these structures at the same time, as they are synthesised.

The final three-dimensional shape of a protein can be classified as globular or fibrous.

Globular Proteins

The vast majority of proteins are globular, i.e. they have a compact, ball-shaped structure. This group includes enzymes, membrane proteins, receptors and storage proteins. The diagram below shows a typical globular enzyme molecule. It has been drawn to highlight the different secondary structures.

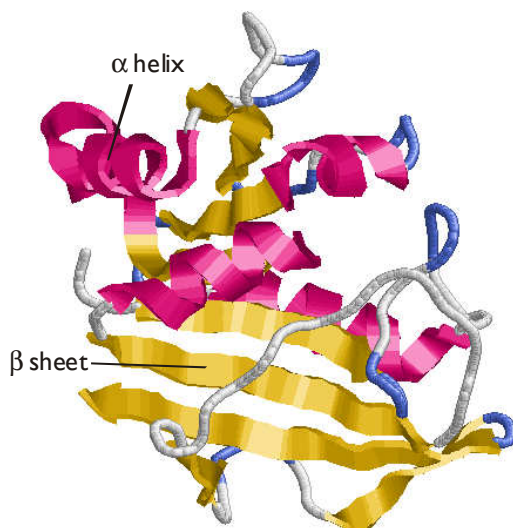

Fibrous (or Filamentous) Proteins

Fibrous proteins are long and thin, like ropes. They tend to have structural roles, such as collagen (bone), keratin (hair), tubulin (cytoskeleton) and actin (muscle). They are always composed of many polypeptide chains. This diagram shows part of a molecule of collagen, which is found in bone and cartilage.



A few proteins have both structures: for example the muscle protein myosin has a long fibrous tail and a globular head, which acts as an enzyme (see unit 4).

Protein Denaturing

Since the secondary, tertiary and quaternary structures are largely held together by hydrogen bonds, the three-dimensional structure of proteins is lost if the hydrogen bonds break. The polypeptide chain just folds up into a random coil and the protein loses its function. This is called denaturing, and happens at temperatures above about 50°C or at very low or high pH. Covalent bonds are not broken under these conditions, so the primary structure is maintained (as are sulphur bridges).

Biochemical Tests

These five tests identify the main biologically-important chemical compounds. For each test take a small sample of the substance to test, and shake it in water in a test tube. If the sample is a piece of food, then grind it with some water in a pestle and mortar to break up the cells and release the cell contents. Many of these compounds are insoluble, but the tests work just as well on a fine suspension.

- 1. Starch** (iodine test). Add a few drops of iodine/potassium iodide solution to the sample. A blue-black colour indicates the presence of starch as a starch-polyiodide complex is formed.
- 2. Reducing Sugars** (Benedict's test). All monosaccharides and most disaccharides (except sucrose) are called reducing sugars because they will reduce ions like Cu^{2+} . Add a few mL of Benedict's reagent (which is a copper (II) sulphate solution) to the sample. Shake, and heat for a few minutes at 95°C in a water bath. A coloured precipitate of copper (I) oxide indicates reducing sugar. The colour and density of the precipitate gives an indication of the amount of reducing sugar present, so this test is semi-quantitative. The original pale blue colour means no reducing sugar, a green precipitate means relatively little sugar; a brown or red precipitate means progressively more sugar is present.
- 3. Non-reducing Sugars** (Benedict's test). Sucrose is called a non-reducing sugar because it does not reduce copper sulphate, so there is no direct test for sucrose. However, if it is first hydrolysed to its constituent monosaccharides (glucose and fructose), it will then give a positive Benedict's test. So sucrose is the only sugar that will give a negative Benedict's test before hydrolysis and a positive test afterwards. First test a sample for reducing sugars, to see if there are any present before hydrolysis. Then, using a separate sample, boil the test solution with dilute hydrochloric acid for a few minutes to hydrolyse the glycosidic bond. Neutralise the solution by gently adding small amounts of solid sodium hydrogen carbonate until it stops fizzing, then test as before for reducing sugars.
- 4. Lipids** (emulsion test). Lipids do not dissolve in water, but do dissolve in ethanol. This characteristic is used in the emulsion test. Do not start by dissolving the sample in water, but instead vigorously shake some of the test sample with about 4 mL of ethanol. Decant the liquid into a second test tube of water, leaving any undissolved substances behind. If there are lipids dissolved in the ethanol, they will precipitate in the water, forming a cloudy white emulsion.
- 5. Protein** (biuret test). Add a few mL of biuret solution to the sample. Shake, and the solution turns lilac-purple, indicating protein. The colour is due to a complex between nitrogen atoms in the peptide chain and Cu^{2+} ions, so this is really a test for peptide bonds.

Enzymes

Enzymes are biological catalysts. There are about 40,000 different enzymes in human cells, each controlling a different chemical reaction. They increase the rate of reactions by a factor of between 10^6 to 10^{12} times, allowing the chemical reactions that make life possible to take place at normal temperatures. They were discovered in fermenting yeast in 1900 by Buchner, and the name enzyme means "in yeast". As well as catalysing all the metabolic reactions of cells (such as respiration, photosynthesis and digestion), they also act as motors, membrane pumps and receptors.

How do enzymes work?

There are three ways of thinking about enzyme catalysis. They all describe the same process, though in different ways, and you should know about each of them.

I. Enzymes Distort the Substrate in the Active Site

Enzymes are proteins, and their function is determined by their complex structure. The reaction takes place in a small part of the enzyme called the active site, while the rest of the protein acts as "scaffolding". The substrate molecule fits into the active site like a key fitting into a lock (in fact it is sometimes called a lock and key mechanism). The amino acids around the active site bind to the substrate molecule (usually by weak hydrogen and ionic bonds), so these amino acids make the enzyme specific for one reaction only, as other molecules won't bind in the active site.

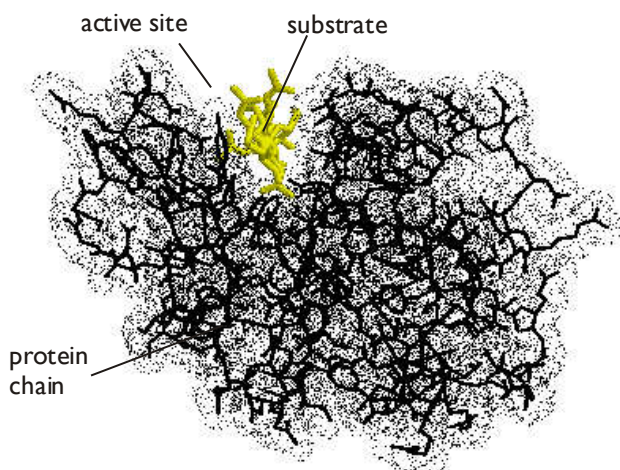

Lysozyme – whole molecule

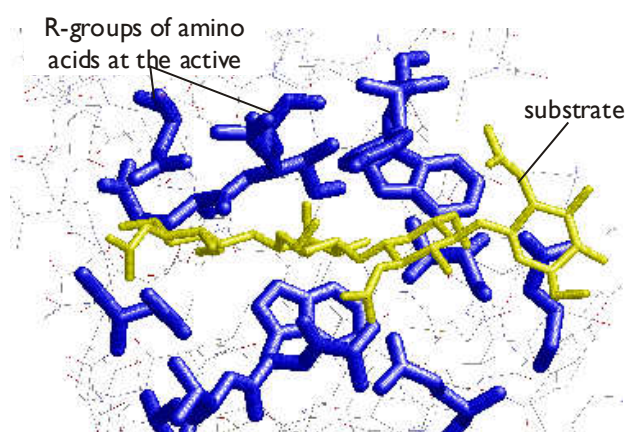

Close-up of substrate binding to amino acids in the active site

Add Induced fit stuff here

The active site actually catalyses the reaction by changing shape slightly after the substrate has bound. This change distorts the substrate molecule in the active site, making it more likely to

change into the product. For example if a bond in the substrate is to be broken, that bond might be stretched by the enzyme, making it more likely to break. Alternatively if a bond is to be made between two molecules, the two molecules can be held in exactly the right position and orientation and “pushed” together, making the bond more likely to form. The enzyme can also make the local conditions inside the active site quite different from those outside (such as pH, water concentration, charge), so that the reaction is more likely to happen.

Many enzymes also have small non-protein molecules called coenzymes at their active sites to help bind to the substrate. Many of these are derived from dietary vitamins, which is why vitamins are so important.

2. Enzymes Take an Alternative Reaction Pathway

In any chemical reaction, a substrate (S) is converted into a product (P):

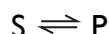

(There may be more than one substrate and more than one product, but that doesn't matter here.) In an enzyme-catalysed reaction, the substrate first binds to the active site of the enzyme to form an enzyme-substrate (ES) complex, then the substrate is converted into product while attached to the enzyme, and finally the product is released. This mechanism can be shown as:



The enzyme is then free to start again. The end result is the same ($S \rightleftharpoons P$), but a different route is taken, so that the $S \rightleftharpoons P$ reaction as such never takes place. In by-passing this step, and splitting the reaction up into many small steps rather than one big step, the reaction can be made to happen much more quickly.

3. Enzymes Lower the Activation Energy

The way enzymes work can also be shown by considering the energy changes that take place during a chemical reaction. We shall consider a reaction where the product has a lower energy than the substrate, so the substrate naturally turns into product (in other words the equilibrium lies in the direction of the product). Before it can change into product, the substrate must overcome an "energy barrier" called the activation energy (E_A). The larger the activation energy, the slower the reaction will be

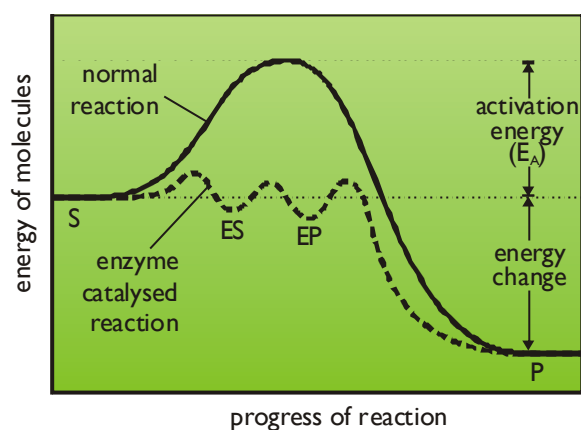

because only a few substrate molecules will by chance have sufficient energy to overcome the activation energy barrier. Imagine pushing boulders over a hump before they can roll down hill, and you have the idea. Most physiological reactions have large activation energies, so they simply don't happen on a useful time scale. Enzymes dramatically reduce the activation energy of a reaction, so that most molecules can easily get over the activation energy barrier and quickly turn into product.

For example for the breakdown of hydrogen peroxide ($2\text{H}_2\text{O}_2 \rightleftharpoons 2\text{H}_2\text{O} + \text{O}_2$):

- $E_A = 86 \text{ kJ mol}^{-1}$ with no catalyst
- $E_A = 62 \text{ kJ mol}^{-1}$ with an inorganic catalyst of iron filings
- $E_A = 1 \text{ kJ mol}^{-1}$ in the presence of the enzyme peroxidase (catalase).

Factors that Affect the Rate of Enzyme Reactions

I. Temperature

All chemical reactions get faster as the temperature increases, but with enzyme reactions this is only true up to a certain temperature, above which the rate slows down again. This optimum temperature is about 40°C for mammalian enzymes but there are enzymes that work best at very different temperatures, e.g. enzymes from the arctic snow flea work at -10°C , and enzymes from thermophilic bacteria work at 90°C .

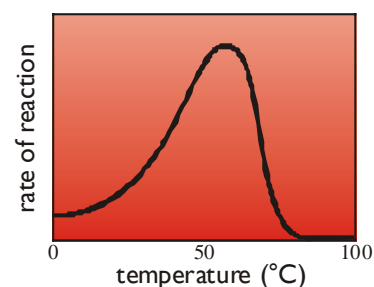

Up to the optimum temperature the rate increases geometrically with temperature (i.e. it's a curve, not a straight line). The rate increases because the enzyme and substrate molecules both have more kinetic energy so collide more often, and also because more molecules have sufficient energy to overcome the (greatly reduced) activation energy. The rate is not zero at 0°C , so enzymes still work in the fridge (and food still goes off), but they work slowly. Enzymes can even work in ice, though the rate is extremely slow due to the very slow diffusion of enzyme and substrate molecules through the ice lattice.

This increase in rate with temperature would continue indefinitely except that the enzyme molecule itself is affected by temperature. Above about 40°C there is enough thermal energy to break the weak hydrogen bonds holding the secondary, tertiary and quaternary structures of

the enzyme together, so the enzyme (and especially the active site) loses its specific shape to become a random coil. The substrate can no longer bind, and the reaction is no longer catalysed. This denaturation is usually irreversible. So the optimum temperature of enzymes is usually about 40°C (and mammals and birds maintain their body temperature at around 40°C) because that is the temperature at which hydrogen bonds break. Remember that only the weak hydrogen bonds not peptide bonds are broken at these mild temperatures; to break strong covalent bonds you need to boil in concentrated acid for many hours.

2. pH

Enzymes have an optimum pH at which they work fastest. For most enzymes this is about pH 7-8 (physiological pH of most cells), but a few enzymes can work at extreme pH, such as protease enzymes in animal stomachs, which have an optimum of pH 1. The pH affects the charge of the R-groups of the amino acids at the active site. For example carboxyl R-groups are uncharged (COOH) in acid pH but negatively charged (COO⁻) in alkali pH. Similarly amino R-groups are positively charged (NH₃⁺) in acidic pH but uncharged (NH₂) in alkali pH. These changes can affect the shape as well as the charge of the active site, so the substrate can no longer bind and the reaction isn't catalysed.

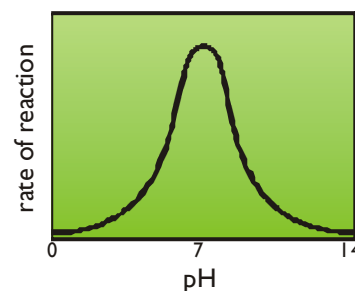

3. Enzyme concentration

As the enzyme concentration increases the rate of the reaction increases linearly, because there are more enzyme molecules available to catalyse the reaction. At very high enzyme concentration the substrate concentration may become rate-limiting, so the rate stops increasing. Normally enzymes are present in cells in rather low concentrations.

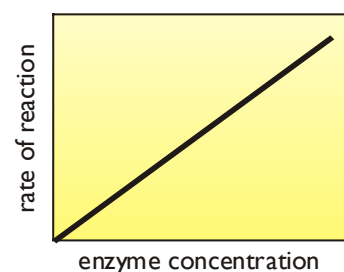

4. Substrate concentration

The rate of an enzyme-catalysed reaction shows a curved dependence on substrate concentration. As the substrate concentration increases, the rate increases because more substrate molecules can collide with enzyme molecules, so more reactions will take place. At higher concentrations the enzyme active sites become saturated with substrate, so there are few free enzyme molecules, so adding more substrate doesn't make much difference (though it will increase the rate of E-S collisions).

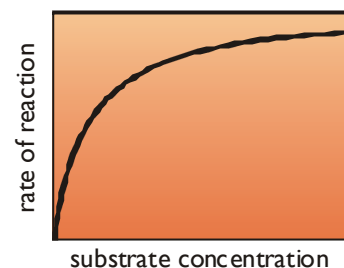

5. Inhibitors

Inhibitors inhibit the activity of enzymes, reducing the rate of their reactions. They are found naturally, but are also used artificially as drugs, pesticides and research tools. Inhibitors that bind fairly weakly and can be washed out are called reversible inhibitors, while those that bind tightly and cannot be washed out are called irreversible inhibitors. There are two kinds of inhibitors:

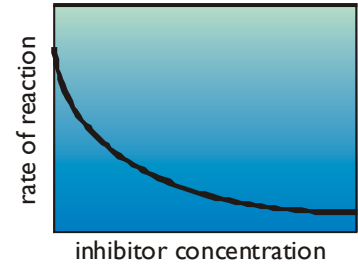

competitive inhibitors

A competitive inhibitor molecule has a similar structure to the normal substrate molecule, and it can fit into the active site of the enzyme. It therefore competes with the substrate for the active site, so the reaction is slower. However, if the substrate concentration is increased high enough the substrate will out-compete the inhibitor and the rate can approach a normal rate. The sulphonamide anti-bacterial drugs are competitive inhibitors.

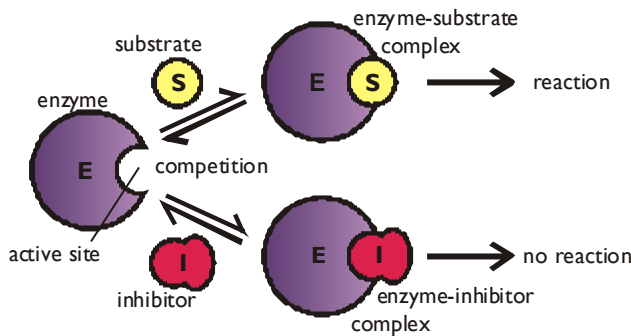

non-competitive inhibitors

A non-competitive inhibitor molecule is quite different in structure from the substrate molecule and does not fit into the active site. It binds to another part of the enzyme molecule, changing the shape of the whole enzyme, including the active site, so that it can no longer bind substrate molecules. Non-competitive inhibitors therefore simply reduce the amount of active enzyme (just like decreasing the enzyme concentration). Poisons like cyanide, heavy metal ions and some insecticides are all non-competitive inhibitors.

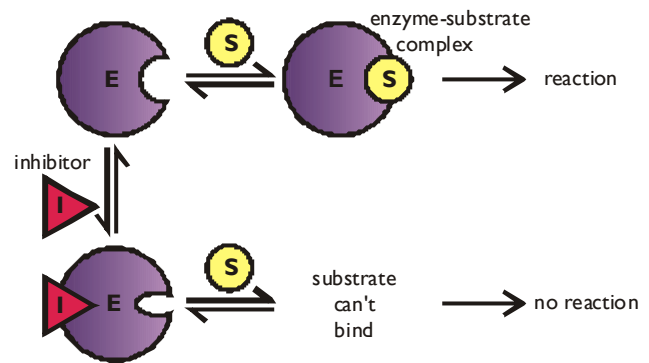

The two types of inhibitor can be distinguished experimentally by carrying out a substrate vs. rate experiment in the presence and absence of the inhibitor. If the inhibition is reduced at high substrate concentration then the inhibitor is a competitive one.

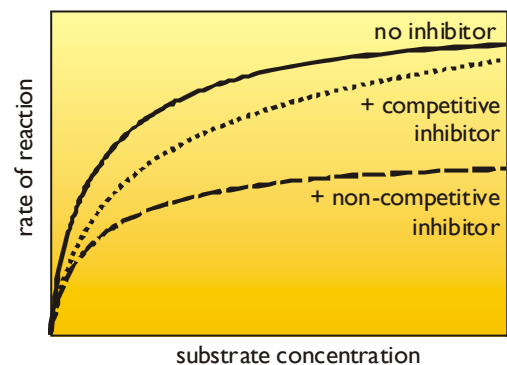

Measuring the Rate of Enzyme Reactions

1. Firstly you need a signal to measure that shows the progress of the reaction. The signal should change with either substrate or product concentration, and it should preferably be something that can be measured continuously. Typical signals include colour changes, pH changes, mass changes, gas production, volume changes or turbidity changes. If the reaction has none of these properties, it can sometimes be linked to a second reaction that does generate one of these changes.

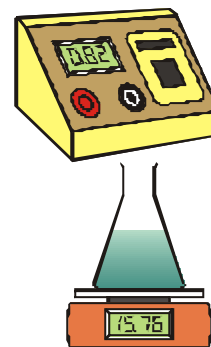

2. If you mix the substrate with enzyme and measure the signal, you will obtain a time-course. If the signal is proportional to substrate concentration it will start high and decrease, while if the signal is proportional to product it will start low and increase. In both cases the time-course will be curved (actually an exponential curve).

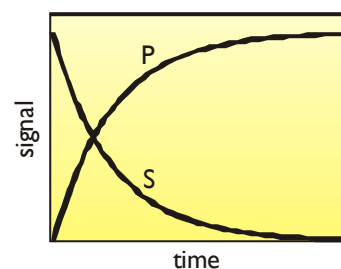

3. How do you obtain a rate from this time-course? One thing that is not a good idea is to measure the time taken for the reaction, for as the time-course shows it is very difficult to say when the reaction actually ends: it just gradually approaches the end-point. The rate is in fact the slope (or gradient) of the time-course, so we can see that the rate (and slope) decreases as the reaction proceeds. The best measurement is the initial rate - that is the initial slope of the time-course. This also means you don't need to record the whole time-course, but simply take one measurement a short time after mixing.

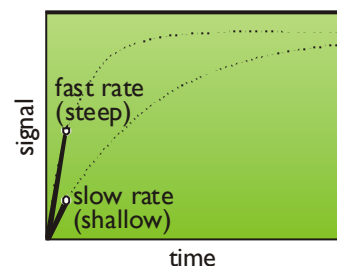

4. Repeat this initial rate measurement under different conditions (such as different temperatures or substrate concentrations) and then plot a graph of rate vs. the factor. Each point on this second graph is taken from a separate initial rate measurement (or better still is an average of several initial rate measurements under the same conditions). Draw a smooth curve through the points.

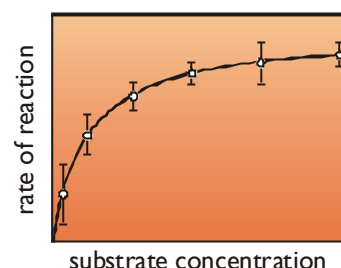

Be careful not to confuse the two kinds of graph (the time-course and rate graphs) when interpreting data.

Cells

All living things are made of cells, and cells are the smallest units that can be alive. There are thousands of different kinds of cell, but the biggest division is between the cells of the prokaryote kingdom (the bacteria) and those of the other four kingdoms (animals, plants, fungi and protocista), which are all eukaryotic cells. Prokaryotic cells are smaller and simpler than eukaryotic cells, and do not have a nucleus.

- Prokaryote = without a nucleus (think "before carrier bag")
- Eukaryote = with a nucleus (think "good carrier bag")

We'll examine these two kinds of cell in detail, based on structures seen in electron micrographs. These show the individual organelles inside a cell.

Euakryotic Cells

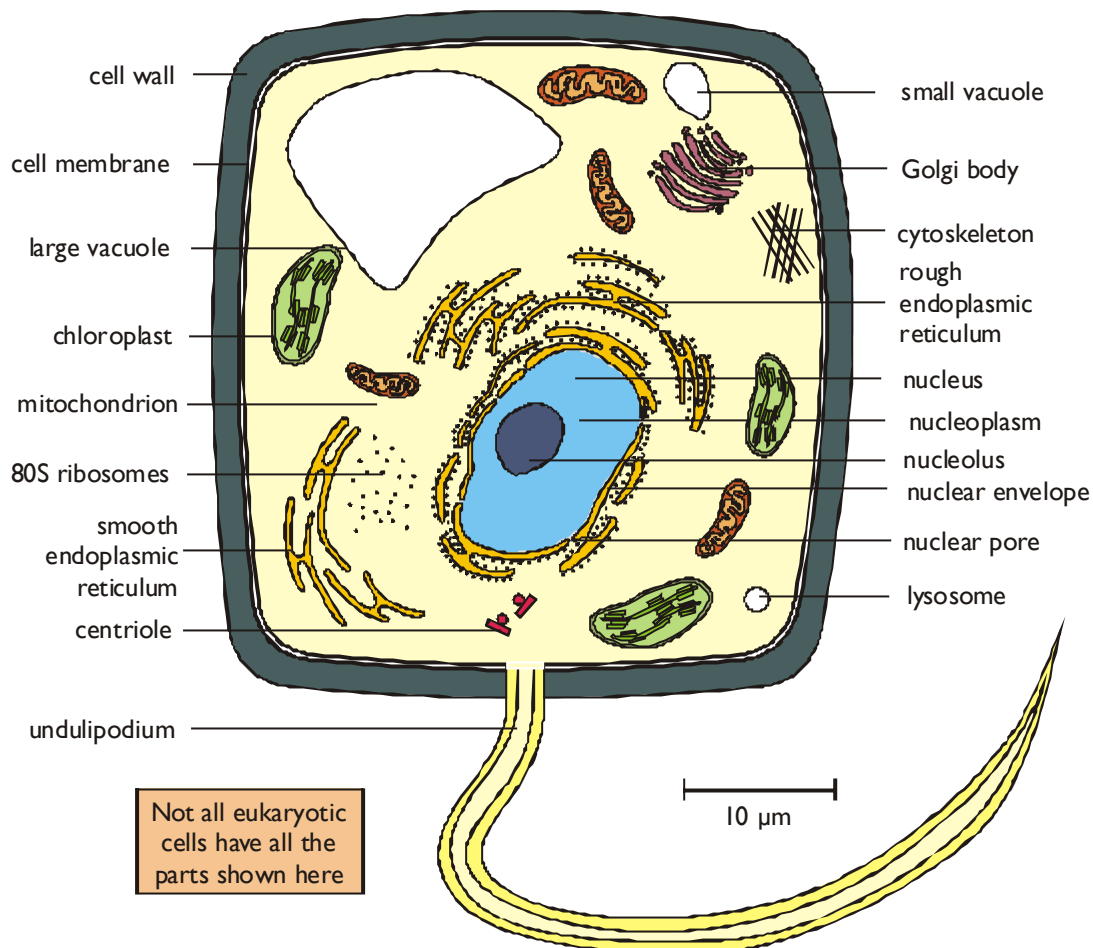

- **Cytoplasm (or Cytosol).** This is the solution within the cell membrane. It contains enzymes for glycolysis (part of respiration) and other metabolic reactions together with sugars, salts, amino acids, nucleotides and everything else needed for the cell to function.

- **Nucleus.** This is the largest organelle. It is surrounded by a nuclear envelope, which is a double membrane with nuclear pores – large holes containing proteins that control the exit of substances such as RNA and ribosomes from the nucleus. The interior is called the nucleoplasm, which is full of chromatin – the DNA/protein complex (see module 2). During cell division the chromatin becomes condensed into discrete observable chromosomes. The nucleolus is a dark region of chromatin, involved in making ribosomes.

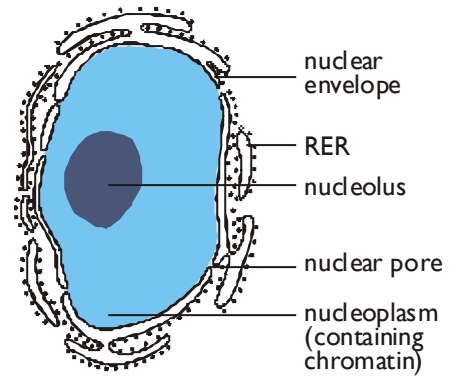

- **Mitochondrion (pl. Mitochondria).** This is a sausage-shaped organelle (8µm long), and is where aerobic respiration takes place in all eukaryotic cells. Mitochondria are surrounded by a double membrane: the outer membrane is simple and quite permeable, while the inner membrane is highly folded into cristae, which give it a large surface area. The space enclosed by the inner membrane is called the mitochondrial matrix, and contains small circular strands of DNA. The inner membrane is studded with stalked particles, which are the site of ATP synthesis.

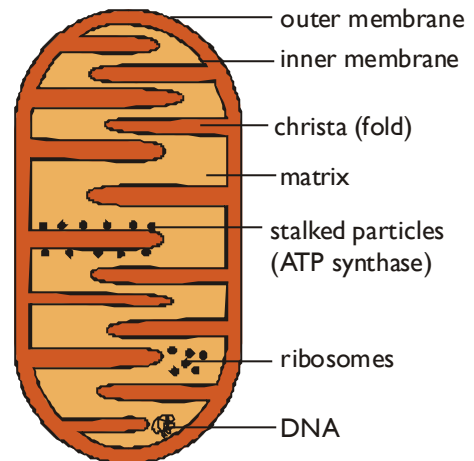

- **Chloroplast.** Bigger and fatter than mitochondria, chloroplasts are where photosynthesis takes place, so are only found in photosynthetic organisms (plants and algae). Like mitochondria they are enclosed by a double membrane, but chloroplasts also have a third membrane called the thylakoid membrane. The thylakoid membrane is folded into thylakoid disks, which are then stacked into piles called grana. The space between the inner membrane and the thylakoid is called the stroma. The thylakoid membrane contains chlorophyll and chloroplasts also contain starch grains, ribosomes and circular DNA.

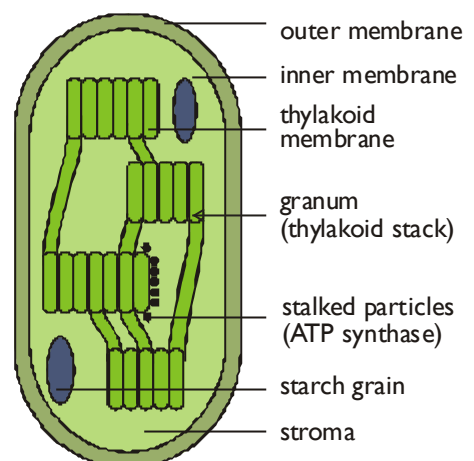

- **Ribosomes.** These are the smallest and most numerous of the cell organelles, and are the sites of protein synthesis. They are composed of protein and RNA, and are manufactured in the nucleolus of the nucleus. Ribosomes are either found free in the cytoplasm, where they make proteins for the cell's own use, or they are found attached to the rough endoplasmic reticulum, where they make proteins for export from the cell. All eukaryotic ribosomes are of the larger, "80S", type.

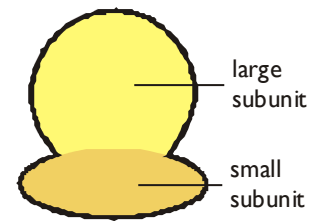

- **Endoplasmic Reticulum (ER).** This is a series of membrane channels involved in synthesising and transporting materials. Rough Endoplasmic Reticulum (RER) is studded with numerous ribosomes, which give it its rough appearance. The ribosomes synthesise proteins, which are processed in the RER (e.g. by enzymatically modifying the polypeptide chain, or adding carbohydrates), before being exported from the cell via the Golgi Body. Smooth Endoplasmic Reticulum (SER) does not have ribosomes and is used to process materials, mainly lipids, needed by the cell.

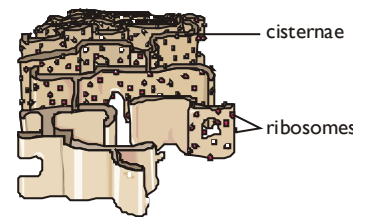

- **Golgi Body (or Golgi Apparatus).** Another series of flattened membrane vesicles, formed from the endoplasmic reticulum. Its job is to transport proteins from the RER to the cell membrane for export. Parts of the RER containing proteins fuse with one side of the Golgi body membranes, while at the other side small vesicles bud off and move towards the cell membrane, where they fuse, releasing their contents by exocytosis.

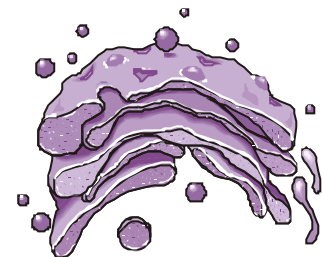

- **Vacuoles.** These are membrane-bound sacs containing water or dilute solutions of salts and other solutes. Most cells can have small vacuoles that are formed as required, but plant cells usually have one very large permanent vacuole that fills most of the cell, so that the cytoplasm (and everything else) forms a thin layer round the outside. Plant cell vacuoles are filled with cell sap, and are very important in keeping the cell rigid, or turgid. Some unicellular protists have feeding vacuoles for digesting food, or contractile vacuoles for expelling water.

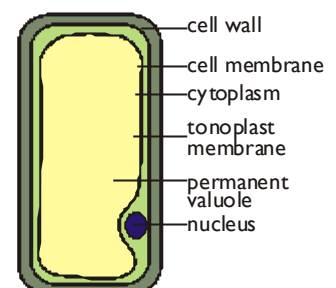

- **Lysosomes.** These are small membrane-bound vesicles formed from the RER containing a cocktail of digestive enzymes. They are used to break down unwanted chemicals, toxins, organelles or even whole cells, so that the materials may be recycled. They can also fuse with a feeding vacuole to digest its contents.
- **Cytoskeleton.** This is a network of protein fibres extending throughout all eukaryotic cells, used for support, transport and motility. The cytoskeleton is attached to the cell membrane and gives the cell its shape, as well as holding all the organelles in position. The cytoskeleton is also responsible for cell movements such as: chromosome movement and cytoplasm cleavage in cell division, cytoplasmic streaming in plant cells, cilia and flagella movements, cell crawling and even muscle contraction in animals.
- **Centriole.** This is a special pair of short cytoskeleton fibres involved in cell division. They initiate the spindle that organises and separates the chromosomes (see unit 2).
- **Undulipodium (Cilium or Flagellum).** This is a long flexible tail present in some cells and used for motility. It is an extension of the cytoplasm, surrounded by the cell membrane, and is full of microtubules and motor proteins so is capable of complex swimming movements. There are two kinds: flagella (no relation of the bacterial flagellum) are longer than the cell, and there are usually only one or two of them (e.g. sperm), while cilia are identical in structure, but are much smaller and there are usually very many of them (e.g. trachea, ciliates).
- **Microvilli.** These are small finger-like extensions of the cell membrane found in certain cells such as in the epithelial cells of the intestine and kidney, where they increase the surface area for absorption of materials. They are just visible under the light microscope as a brush border. Don't confuse microvilli (sub-cellular structures) with villi (much bigger multi-cellular structures).

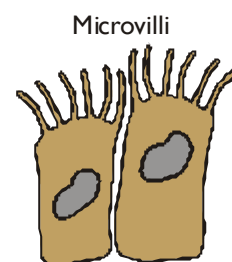
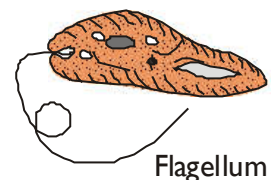
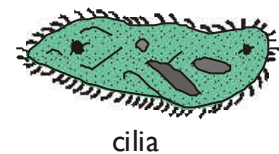
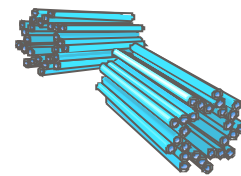
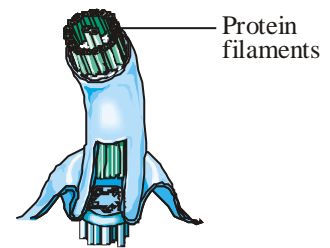
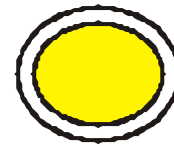

- **Cell Membrane (or Plasma Membrane).** This is a thin, flexible layer round the outside of all cells made of phospholipids and proteins. It separates the contents of the cell from the outside environment, and controls the entry and exit of materials. The membrane is examined in detail later.
- **Cell Wall.** This is a thick layer outside the cell membrane used to give a cell strength and rigidity. Cell walls consist of a network of fibres, which give strength but are freely permeable to solutes (unlike membranes). A wickerwork basket is a good analogy. Plant cell walls are made mainly of cellulose, but can also contain hemicellulose, pectin, lignin and other polysaccharides. There are often channels through plant cell walls called plasmodesmata, which link the cytoplasms of adjacent cells. Fungal cell walls are made of chitin.

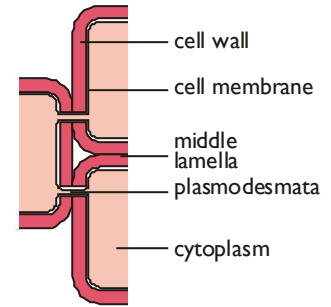
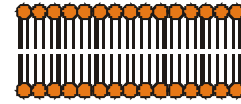

Comparison of different types of Eukaryotic Cell

	Fungi	Plants	Animals
Nucleus	✓	✓	✓
Mitochondria	✓	✓	✓
Chloroplast	x	✓	x
80S ribosome	✓	✓	✓
Vacuoles	✓	✓	x
Cytoskeleton	✓	✓	✓
Undulipodium	x	x	✓
Plasma membrane	✓	✓	✓
Cell Wall	✓ (chitin)	✓ (cellulose)	x

Prokaryotic Cells

Prokaryotic cells are smaller than eukaryotic cells and do not have a nucleus or indeed any membrane-bound organelles. All prokaryotes are bacteria. Prokaryotic cells are much older than eukaryotic cells and they are far more abundant (there are ten times as many bacteria cells in a human than there are human cells). The main features of prokaryotic cells are:

- **Cytoplasm.** Contains all the enzymes needed for all metabolic reactions, since there are no organelles
- **Ribosomes.** The smaller (70S) type, all free in the cytoplasm and never attached to membranes. Used for protein synthesis.
- **Nuclear Zone (or Nucleoid).** The region of the cytoplasm that contains DNA. It is not surrounded by a nuclear membrane.
- **DNA.** Always circular (i.e. a closed loop), and not associated with any proteins to form chromatin. Sometimes confusingly referred to as the bacterial chromosome.
- **Plasmid.** Small circles of DNA, separate from the main DNA loop. Used to exchange DNA between bacterial cells, and also very useful for genetic engineering (see unit 4).
- **Plasma membrane.** Made of phospholipids and proteins, like eukaryotic membranes.
- **Cell Wall.** Made of murein (not cellulose), which is a glycoprotein (i.e. a protein/carbohydrate complex, also called peptidoglycan).
- **Capsule.** A thick polysaccharide layer outside of the cell wall. Used for sticking cells together, as a food reserve, as protection against desiccation and chemicals, and as protection against phagocytosis. In some species the capsules of many cells fuse together forming a mass of sticky cells called a biofilm. Dental plaque is an example of a biofilm.
- **Flagellum.** A rigid rotating helical-shaped tail used for propulsion. The motor is embedded in the cell membrane and is driven by a H^+ gradient across the membrane. Anticlockwise rotation drives the cell forwards, while clockwise rotation causes a chaotic spin.

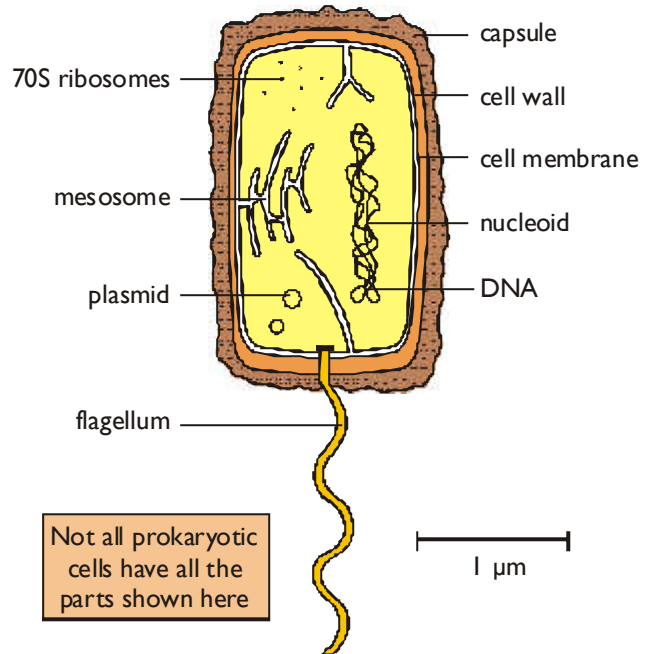

Summary of the Differences Between Prokaryotic and Eukaryotic Cells

Prokaryotic Cells	Eukaryotic cells
small cells (< 5 μm)	larger cells (> 10 μm)
always unicellular	often multicellular
no nucleus or any membrane-bound organelles	always have nucleus and other membrane-bound organelles
DNA is circular, without proteins	DNA is linear and associated with proteins to form chromatin
ribosomes are small (70S)	ribosomes are large (80S)
no cytoskeleton	always has a cytoskeleton
motility by rigid rotating flagellum, made of flagellin	motility by flexible waving undulipodium, made of tubulin
cell division is by binary fission	cell division is by mitosis or meiosis
reproduction is always asexual	reproduction is asexual or sexual
huge variety of metabolic pathways	common metabolic pathways

Endosymbiosis

Prokaryotic cells are far older and more diverse than eukaryotic cells. Prokaryotic cells have probably been around for 3.5 billion years, while eukaryotic cells arose only about 1 billion years ago. It is thought that eukaryotic cell organelles like nuclei, mitochondria and chloroplasts are derived from prokaryotic cells that became incorporated inside larger prokaryotic cells. This idea is called endosymbiosis, and is supported by these observations:

- organelles contain circular DNA, like bacteria cells.
- organelles contain 70S ribosomes, like bacteria cells.
- organelles have double membranes, as though a single-membrane cell had been engulfed and surrounded by a larger cell.
- organelles reproduce by binary fission, like bacteria.
- organelles are very like some bacteria that are alive today.

Cell Fractionation

This means separating different parts and organelles of a cell, so that they can be studied in detail. All the processes of cell metabolism (such as respiration or photosynthesis) have been studied in this way. The most common method of fractionating cells is to use differential centrifugation:

1. Cut tissue (eg liver, heart, leaf, etc) in ice-cold isotonic buffer. Cold to stop enzyme reactions, isotonic to stop osmosis, and buffer to stop pH changes.

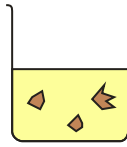

2. Grind tissue in a blender to break open cells.



3. Filter. This removes insoluble tissue (eg fat, connective tissue, plant cell walls, etc). This filtrate is now called a cell-free extract and is capable of carrying out most of the normal cell reactions.



4. Centrifuge filtrate at low speed (1 000xg for 10 mins).

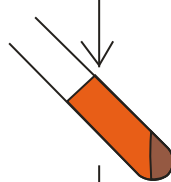

This pellets nuclei, which can be resuspended



5. Centrifuge supernatant at medium speed (10 000 xg for 30 mins).

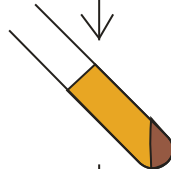

This pellets mitochondria and chloroplasts, which can be resuspended



6. Centrifuge supernatant at high speed (100 000xg for 1 hour).

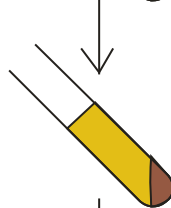

This pellets ER, golgi and other membrane fragments, which can be resuspended



7. Centrifuge supernatant at very high speed (300 000xg for 3 hrs).

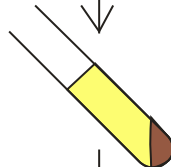

This pellets ribosomes, which can be resuspended



8. Supernatant is now organelle-free cytoplasm



Microscopy

Of all the techniques used in biology microscopy is probably the most important. The vast majority of living organisms are too small to be seen in any detail with the human eye, and cells and their organelles can only be seen with the aid of a microscope. Cells were first seen in 1665 by Robert Hooke (who named them after monks' cells in a monastery), and were studied in more detail by Leeuwenhoek using a primitive microscope.

Units of measurement. The standard SI units of measurement used in microscopy are:

metre	m	= 1 m
millimetre	mm	= 10^{-3} m (never use cm!)
micrometre	μm	= 10^{-6} m
nanometre	nm	= 10^{-9} m
picometre	pm	= 10^{-12} m
angstrom	Å	= 10^{-10} m (obsolete)

Magnification and Resolution. The magnification of a microscope simply indicates how much bigger the image is than the original object. It is usually given as a magnification factor, e.g. $\times 100$. By using more lenses microscopes can magnify by a larger amount, but this doesn't always mean that more detail can be seen. The amount of detail depends on the resolution of a microscope, which is the smallest separation at which two separate objects can be distinguished (or resolved). Resolution is therefore a distance (usually in nm) and is calculated by the formula:

$$\text{resolution} = \frac{0.6\lambda}{n.a.} \quad (\text{you don't need to know this formula})$$

where λ is the wavelength of light, and *n.a.* is the numerical aperture of the lens (which ranges from about 0.5 to 1.4). So the resolution of a microscope is ultimately limited by the wavelength of light (400-600nm for visible light). To improve the resolution a shorter wavelength of light is needed, and sometimes microscopes have blue filters for this purpose (because blue has the shortest wavelength of visible light).

Different kinds of Microscope.

1. Light Microscope. This is the oldest, simplest and most widely-used form of microscopy. Specimens are illuminated with light, which is focused using glass lenses and viewed using the eye or photographic film. Specimens can be living or dead, but often need to be coloured with a coloured stain to make them visible. Many different stains are available that stain specific parts of the cell such as DNA, lipids, cytoskeleton, etc. All light microscopes today are compound microscopes, which means they use several lenses to obtain high magnification.

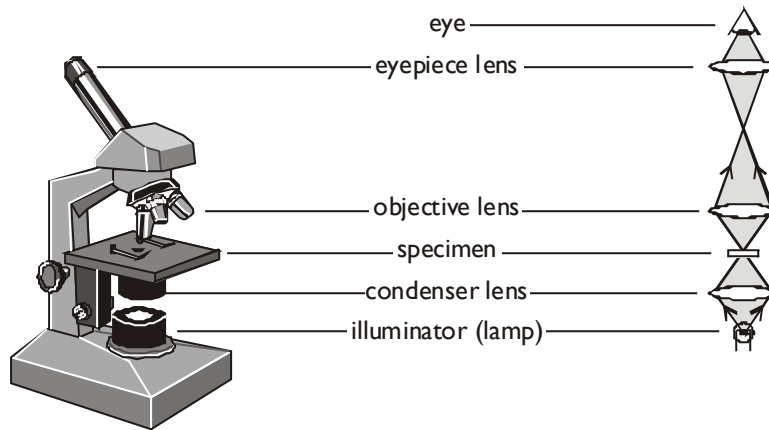

Light microscopy has a resolution of about 200 nm, which is good enough to see tissues and cells, but not the details of cell organelles. There has been a recent resurgence in the use of light microscopy, partly due to technical improvements, which have dramatically improved the resolution far beyond the theoretical limit. For example fluorescence microscopy has a resolution of about 10 nm, while interference microscopy has a resolution of about 1 nm.

2. Electron Microscope. This uses a beam of electrons, rather than electromagnetic radiation, to "illuminate" the specimen. This may seem strange, but electrons behave like waves and can easily be produced (using a hot wire), focused (using electromagnets) and detected (using a phosphor screen or photographic film).

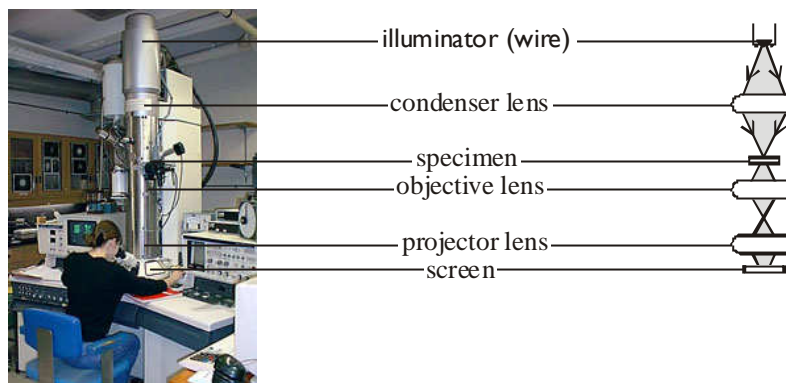

A beam of electrons has an effective wavelength of less than 1 nm, so can be used to resolve small sub-cellular ultrastructure. The development of the electron microscope in the 1930s revolution-

ised biology, allowing organelles such as mitochondria, ER and membranes to be seen in detail for the first time.

There are several problems with the electron microscopy:

- the electron beam is scattered by air molecules, so to avoid this there is a vacuum inside an electron microscope, so it can't be used for living organisms.
- specimens must be very thin, so are embedded in plastic for support, so can't be manipulated under the microscope.
- specimens can be damaged by the electron beam, so delicate structures and molecules can be destroyed.
- specimens are usually transparent to electrons, so must be stained with an electron-dense chemical (usually heavy metals like osmium, lead or gold).
- Initially there was a problem of artefacts (i.e. observed structures that were due to the preparation process and were not real), but improvements in technique have eliminated most of these.

There are two kinds of electron microscope. The transmission electron microscope (TEM) works much like a light microscope, transmitting a beam of electrons through a thin specimen and then focusing the electrons to form an image on a screen or on film. This is the most common form of electron microscope and has the best resolution. The scanning electron microscope (SEM) scans a fine beam of electron onto a specimen and collects the electrons scattered by the surface. This has poorer resolution, but gives excellent 3-dimensional images of surfaces.

Comparison of Light and Electron Microscopes

	light microscope	electron microscope
illumination and source	light from lamp	electrons from hot wire
focusing	glass lenses	electromagnets
detection	eye or film	phosphor screen or film
magnification	1 500 ×	500 000 ×
resolution	200 nm	1 nm
used to observe	tissues, cells and small organisms	cell organelles, microbes and viruses
specimen	living or dead	dead
staining	coloured dyes	heavy metals
cost	cheap to expensive	very expensive

Magnification Calculations

Microscope drawings and photographs (micrographs) are usually magnified, and you have to be able to calculate the actual size of the object from the drawing. There are two ways of doing this:

1. Using a Magnification Factor

Sometimes the image has a magnification factor on it. The formula for the magnification is:

$$\text{magnification} = \frac{\text{image length}}{\text{actual length}}, \text{ or } \begin{array}{c} \text{I} \\ \text{M} \quad \text{A} \end{array}$$

For example if this drawing of an object is 40 mm long and the magnification is $\times 1000$, then the object's actual length is:

$$\frac{I}{M} = \frac{40}{1000} = 0.04\text{mm} = 40\mu\text{m}. \text{ Always convert your answer to appropriate units, usually } \mu\text{m} \text{ for cells and organelles.}$$



$\times 1000$

Sometimes you have to calculate the magnification. For example if this drawing of an object is 40 mm long and its actual length is 25 μm , the magnification of the drawing is:

$$\frac{I}{A} = \frac{40}{0.025} = \times 1600. \text{ Remember, the image and actual length must be in the same units. Magnifications can also be less than one (e.g. } \times 0.1), \text{ which means that the drawing is smaller than the actual object.}$$



2. Using a Scale Bar

Sometimes the picture has a scale bar on it. The formula for calculating the actual length is:

$$\text{actual size} = \frac{\text{image length}}{\text{bar length}} \times \text{bar scale}. \text{ The image size and bar length must be measured in the same units (usually mm), and the actual size will come out in the same units as the bar scale.}$$

For example if this drawing of an object is 40 mm long and the 5 μm scale bar is 10 mm long, then the object's actual size is:

$$\frac{40}{10} \times 5\mu\text{m} = 20\mu\text{m}.$$

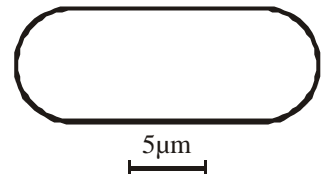

It's good to have a rough idea of the size of objects, to avoid silly mistakes. A mitochondrion is not 30 mm long! Scale bars make this much easier than magnification factors.

The Cell Membrane

The cell membrane (or plasma membrane) surrounds all living cells, and is the cell's most important organelle. It controls how substances can move in and out of the cell and is responsible for many other properties of the cell as well. The membranes that surround the nucleus and other organelles are almost identical to the cell membrane. Membranes are composed of phospholipids, proteins and carbohydrates arranged as shown in this diagram.

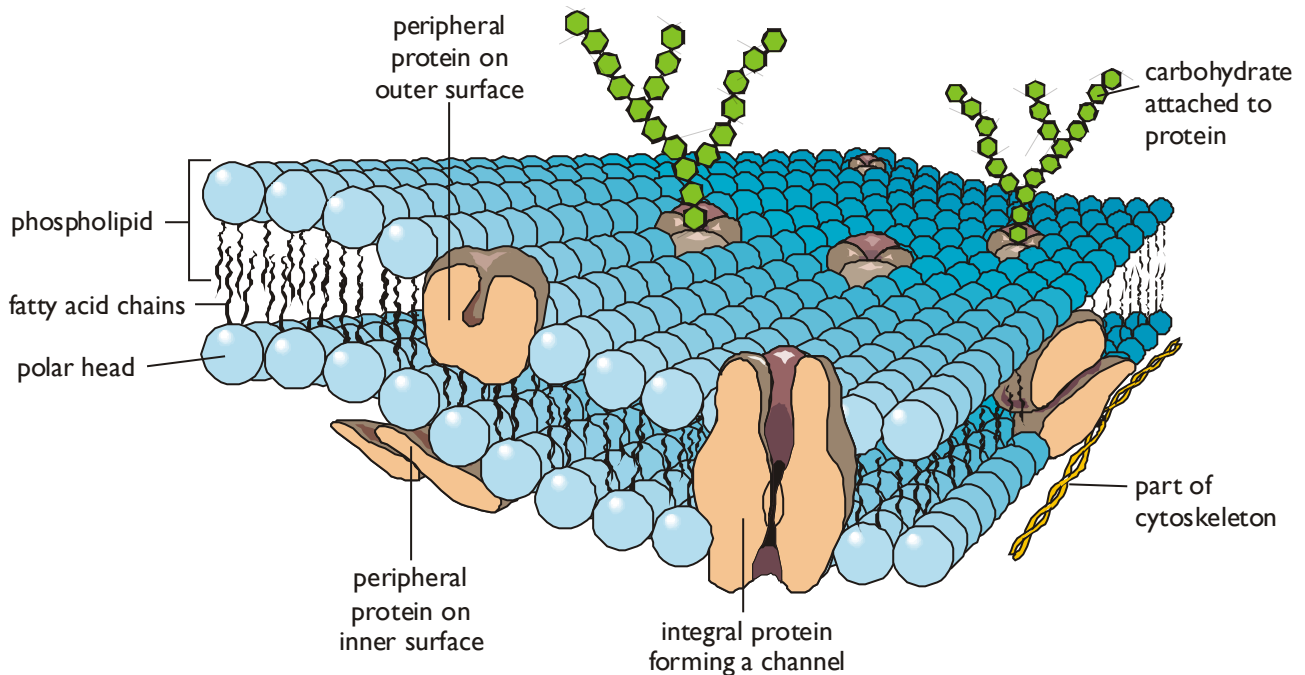

The phospholipids form a thin, flexible sheet, while the proteins "float" in the phospholipid sheet like icebergs, and the carbohydrates extend out from the proteins. This structure is called a fluid mosaic structure because all the components can move around (it's fluid) and the many different components all fit together, like a mosaic.

The phospholipids are arranged in a bilayer (i.e. a double layer), with their polar, hydrophilic phosphate heads facing out towards water, and their non-polar, hydrophobic fatty acid tails facing each other in the middle of the bilayer. This hydrophobic layer acts as a barrier to most molecules, effectively isolating the two sides of the membrane. Different kinds of membranes can contain phospholipids with different fatty acids, affecting the strength and flexibility of the membrane, and animal cell membranes also contain cholesterol linking the fatty acids together and so stabilising and strengthening the membrane.

The proteins usually span from one side of the phospholipid bilayer to the other (integral proteins), but can also sit on one of the surfaces (peripheral proteins). They can slide around the

membrane very quickly and collide with each other, but can never flip from one side to the other. The proteins have hydrophilic amino acids in contact with the water on the outside of membranes, and hydrophobic amino acids in contact with the fatty chains inside the membrane. Proteins comprise about 50% of the mass of membranes, and are responsible for most of the membrane's properties.

- **Proteins can be transporters.** Transport proteins must span the membrane (more details below).

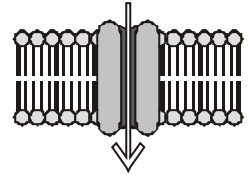

- **Proteins can be receptors.** Receptor proteins must be on the outside surface of cell membranes and have a specific binding site where hormones or other chemicals can bind to form a hormone-receptor complex (like an enzyme-substrate complex). This binding then triggers other events in the cell membrane or inside the cell.

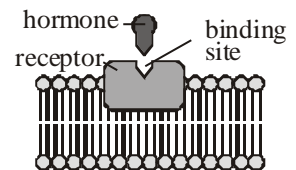

- **Proteins can be enzymes.** Enzyme proteins catalyse reactions in the cytoplasm or outside the cell, such as maltase in the small intestine (more in digestion).

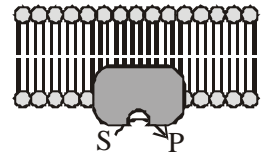

- **Proteins can be antigens.** Antigen proteins are involved in cell recognition and are often glycoproteins, such as the A and B antigens on red blood cell membranes.

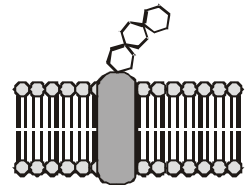

- **Proteins can be structural.** Structural proteins are on the inside surface of cell membranes and are attached to the cytoskeleton. They are involved in maintaining the cell's shape, or in changing the cell's shape for cell motility.

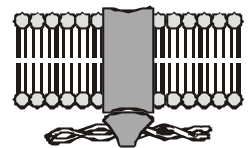

The carbohydrates are found on the outer surface of all eukaryotic cell membranes, and are attached to the membrane proteins or sometimes to the phospholipids. Proteins with carbohydrates attached are called glycoproteins, while phospholipids with carbohydrates attached are called glycolipids.

Remember that a membrane is not just a lipid bilayer, but comprises the lipid, protein and carbohydrate parts.

Movement across Cell Membranes.

Substances move around inside cells by diffusion, which is the random movement of particles due to thermal motion. Diffusion does not require any energy (other than the thermal energy of the surroundings), so it is referred to as a passive process. If there is a concentration difference between two places then the random movement results in the substance diffusing down its concentration gradient from a high to a low concentration:

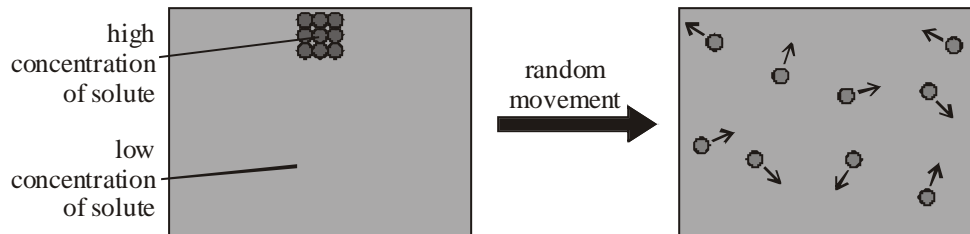

Cell membranes are a barrier to most substances, so we say that membranes are selectively permeable. This means that cell membranes can allow some substances through but not others. This selective permeability allows materials to be concentrated inside cells, excluded from cells, or simply separated from the outside environment. This is compartmentalisation is essential for life, as it enables reactions to take place that would otherwise be impossible. Eukaryotic cells can also compartmentalise materials inside organelles.

Obviously materials need to be able to enter and leave cells, and there are four main methods by which substances can move across a cell membrane:

1. Lipid Diffusion
2. Osmosis (Water Diffusion)
3. Facilitated Diffusion
4. Active Transport

1. Lipid Diffusion (Simple Diffusion)

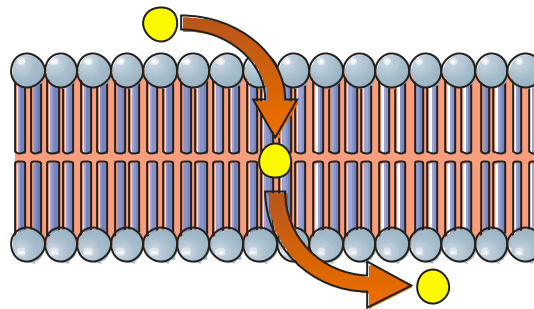

A few substances can diffuse directly through the lipid bilayer part of the membrane. The only substances that can do this are lipid-soluble molecules such as steroids, or very small molecules, such as H₂O, O₂ and CO₂. For these molecules the membrane is no barrier at all. Since lipid diffusion

is a passive process, no energy is involved and substances can only move down their concentration gradient. Lipid diffusion cannot be controlled by the cell, in the sense of being switched on or off.

2. Osmosis (Water Diffusion)

Osmosis is the diffusion of water across a membrane. It is in fact just normal lipid diffusion, but since water is so important and so abundant in cells (its concentration is about 50 mol L⁻¹), the diffusion of water has its own name – osmosis. The contents of cells are essentially solutions of numerous different solutes, and each solute molecule attracts a hydration shell of water molecules attached to it. The more concentrated the solution, the more solute molecules there are in a given volume, and the more water molecules are tied up in hydration shell, so the fewer free water molecules there are. Free water molecules can diffuse easily across a membrane in both directions, but the net movement is always down their concentration gradient, so water therefore diffuses from a dilute to a concentrated solution.

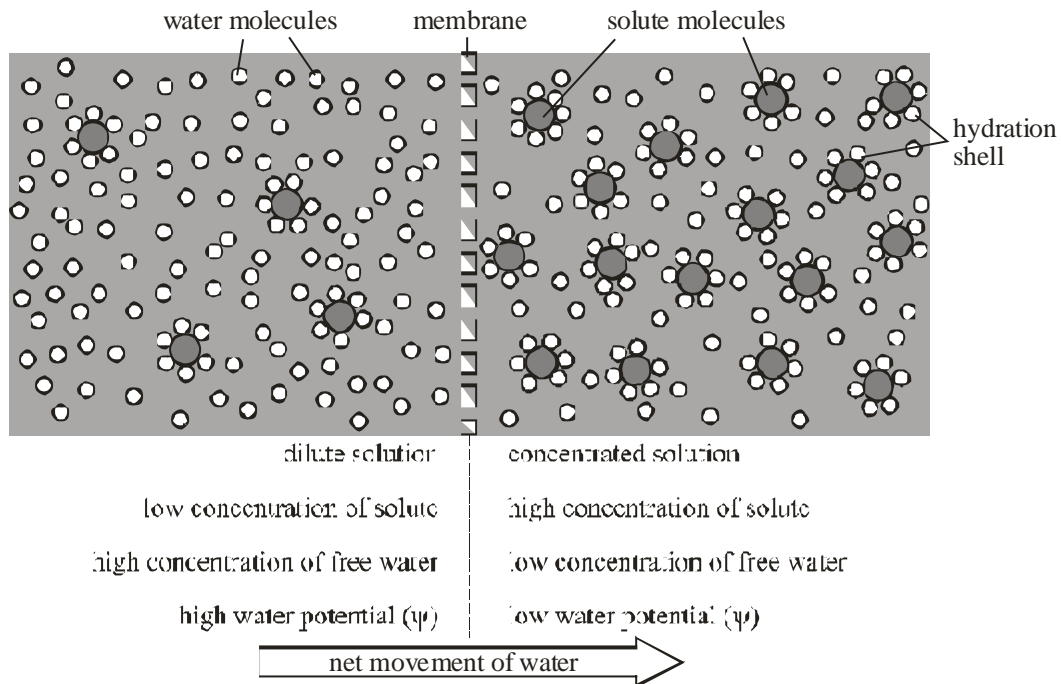

Water Potential. Osmosis can be quantified using water potential, so we can calculate which way water will move, and how fast. Water potential (Ψ , the Greek letter psi, pronounced "sy") is simply the effective concentration of free water. It is measured in units of pressure (Pa, or usually kPa), and the rule is that water always "falls" from a high to a low water potential (in other words it's a bit like gravity potential or electrical potential). 100% pure water has $\Psi = 0$, which is the highest possible water potential, so all solutions have $\Psi < 0$, and you cannot get $\Psi > 0$. An example of water potentials is shown in this diagram:

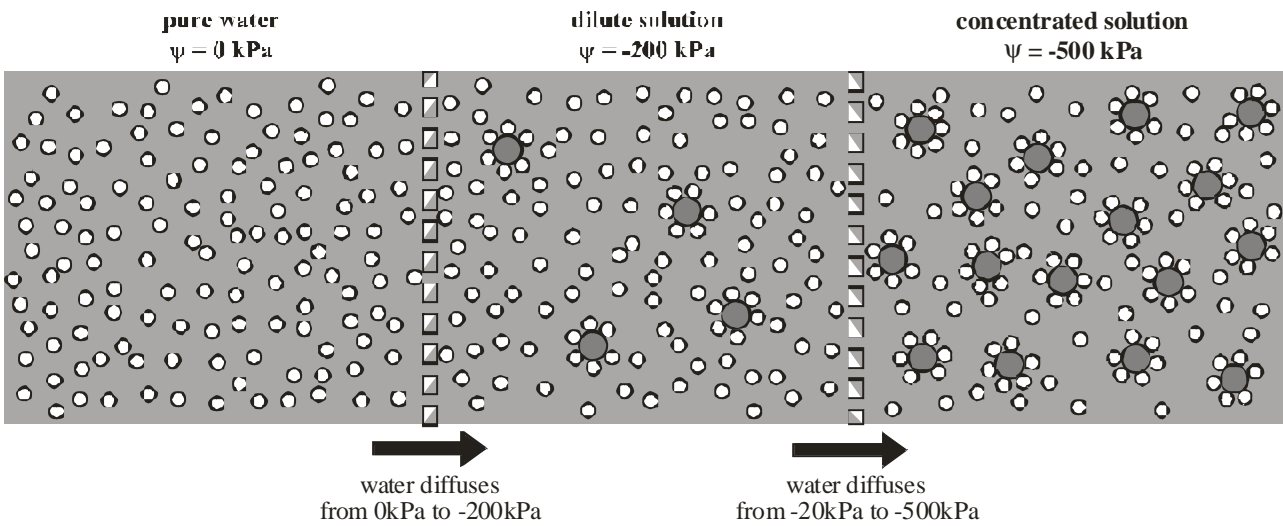

Cells and Osmosis. The water potential of the solution that surrounds a cell affects the state of the cell, due to osmosis. The effects of these solutions on cells are shown in this diagram:

	Surrounding solution has high ψ (e.g. seawater)	Surrounding solution has equal ψ	Surrounding solution has low ψ (e.g. freshwater)
Animal cell	<p>Net diffusion of water into cell, so cell swells and bursts (lysis)</p>	<p>No net diffusion of water, so cell is normal size</p>	<p>Net diffusion of water out of cell, so cell shrinks and <u>crenates</u>.</p>
Plant cell	<p>Net diffusion of water into cell, so cell swells a bit and becomes turgid.</p>	<p>No net diffusion of water, so cell is normal size</p>	<p>Net diffusion of water out of cell, so cytoplasm shrinks from cell wall and cell <u>plasmolyses</u>.</p>

These are problems that living cells face all the time. For example:

- Simple animal cells (protozoans) in fresh water habitats are surrounded by a hypotonic solution (high ψ so water tends to diffuse in by osmosis. These cells constantly need to expel water using contractile vacuoles to prevent swelling and lysis.
- Cells in marine environments are surrounded by a hypertonic solution (low ψ , so water tends to diffuse out by osmosis. These cells must actively pump ions into their cells to reduce their water potential and so reduce water loss by osmosis.

- Young non-woody plants rely on cell turgor for their support, and without enough water they wilt. Plants take up water through their root hair cells by osmosis, and must actively pump ions into their cells to keep them hypertonic compared to the soil. This is particularly difficult for plants rooted in salt water.

3. Facilitated Diffusion (or Passive Transport).

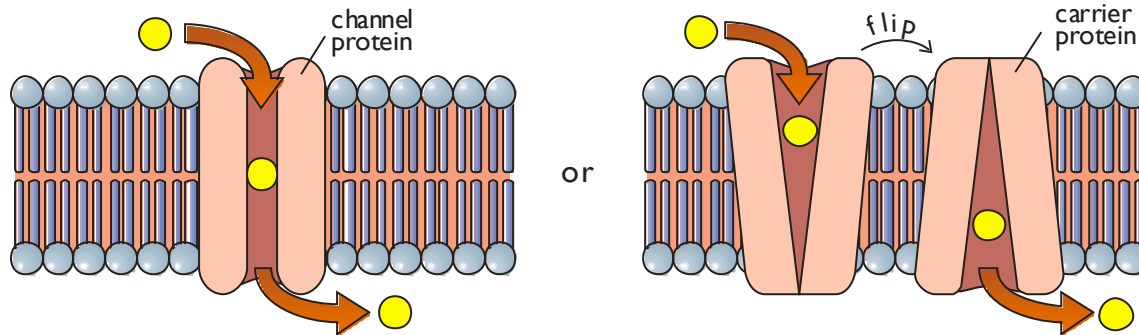

Facilitated Diffusion is the diffusion of substances across a membrane through a trans-membrane protein molecule. The transport proteins tend to be specific for one molecule (a bit like enzymes), so substances can only cross a membrane that contains an appropriate protein. This is a passive diffusion process, so no energy is involved and substances can only move down their concentration gradient. There are two kinds of transport protein:

- Channel Proteins form a water-filled pore or channel in the membrane. This allows charged substances to diffuse across membranes. Most channels can be gated (opened or closed), allowing the cell to control the entry and exit of ions. In this way cells can change their permeability to certain ions. Ions like Na^+ , K^+ , Ca^{2+} and Cl^- diffuse across membranes through specific ion channels.
- Carrier Proteins have a binding site for a specific solute and constantly flip between two states so that the site is alternately open to opposite sides of the membrane. The substance will bind on the side where it is at a high concentration and be released where it is at a low concentration. Important solutes like glucose and amino acids diffuse across membranes through specific carriers. Sometimes carrier proteins have two binding sites and so carry two molecules at once. This is called cotransport, and a common example is the sodium/glucose cotransporter found in the small intestine (see next page). Both molecules must be present for transport to take place.

4. Active Transport.

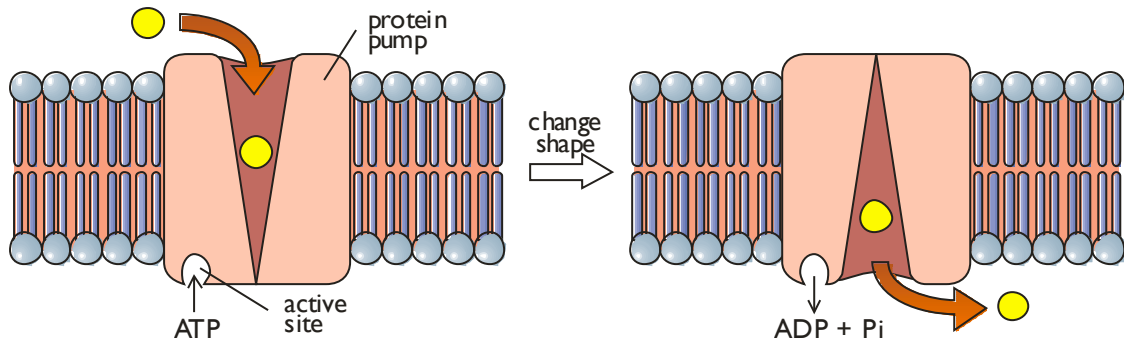

Active transport is the pumping of substances across a membrane by a trans-membrane protein pump molecule, using energy. The protein binds a molecule of the substance to be transported on one side of the membrane, changes shape, and releases it on the other side. The proteins are highly specific, so there is a different protein pump for each molecule to be transported. The protein pumps are also ATPase enzymes, since they catalyse the splitting of $\text{ATP} \rightarrow \text{ADP} + \text{phosphate (Pi)}$, and use the energy released to change shape and pump the molecule. Active transport is therefore not diffusion, but instead is an active process, and is the only transport mechanism that can transport substances up their concentration gradient.

Coupled Active Transport

Some active transport proteins are driven by ATP-splitting directly (as shown above), but others use ATP indirectly. This indirect active transport is called coupled active transport. A good example is the active uptake of glucose in the small intestine, which is coupled to the active transport of sodium ions.

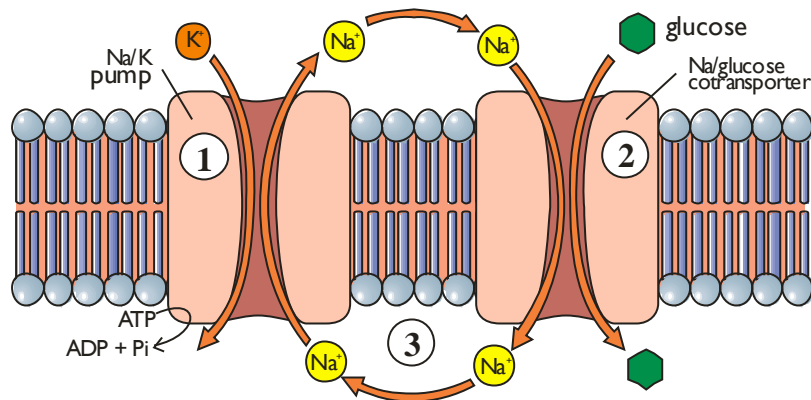

1. All animal cell membranes contain a sodium/potassium ATPase (Na/K pump). This pump continually uses ATP to actively pump sodium ions out of the cell and potassium ions into the cell. This creates a sodium ion gradient across the cell membrane, so there is a tendency for sodium ions to diffuse down their gradient back into the cell.
2. The only route the sodium ions can take is through the sodium/glucose cotransporter, and for every sodium ion that enters a glucose molecule must also be carried in. But while the sodium

ions are diffusing down their concentration gradient, the glucose molecules can be carried up their concentration gradient.

- The sodium ions are pumped out again by the Na/K pump, so they simply cycle in and out of the cell.

The net effect of this coupled active transport is the transport of glucose up its concentration gradient, using energy from ATP splitting – indirect active transport.

Effect of concentration difference on rate of transport

The rate of diffusion of a substance across a membrane increases as its concentration gradient increases, but whereas lipid diffusion shows a linear relationship, facilitated diffusion has a curved relationship with a maximum rate. This is due to the rate being limited by the number of transport proteins. The rate of active transport has a high rate even when there is no concentration difference across the membrane. Active transport stops if cellular respiration stops, since there is no energy.

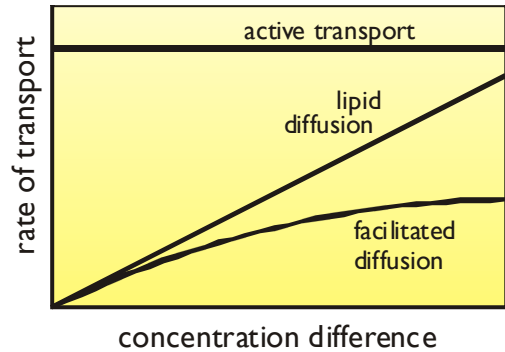

Summary of Membrane Transport

method	uses energy	uses proteins	specific	controllable	gradient
Lipid Diffusion	x	x	x	x	↓
Osmosis	x	x	✓	x	↓
Facilitated Diffusion	x	✓	✓	✓	↓
Active Transport	✓	✓	✓	✓	↑

Exchange

All organisms need to exchange substances such as food, waste, gases and heat with their surroundings. These substances must diffuse between the organism and the surroundings. The rate at which a substance can diffuse is given by Fick's law:

$$\text{Rate of Diffusion} \propto \frac{\text{surface area} \times \text{concentration difference}}{\text{distance}}$$

From Fick's law we can predict that, in order to support a fast rate of diffusion, exchange surfaces must have:

- a large surface area
- a small distance between the source and the destination
- a mechanism to maintain a high concentration gradient across the gas exchange surface.

This table summarises how these requirements are met in the human digestive and gas exchange systems.

system	large surface area	small distance	high concentration gradient
Human small intestine	7m long, folds, villi and microvilli give surface area of 2000m ²	blood capillaries close to surface of villus	stirred by peristalsis and by microvilli
Human circulatory system	100m of capillaries with a surface area of 6000m ²	capillary walls are only one cell thick	constant blood flow replenishes the blood
Human lungs	600 million alveoli with a total area of 100m ²	each alveolus is only one cell thick	constant ventilation replaces the air

For comparison, a tennis court has an area of about 260 m² and a football pitch has an area of about 5000 m².

Physiology and Disease

Physiology is the study of how the body's tissues, organs and systems work. In the rest of this unit we shall look at the digestive system; the gas exchange system and the circulatory system. But we shall also look at diseases of these systems. Disease is a general term meaning a disorder of the body. Diseases can be caused by many different factors:

- **Infectious Diseases** are caused by pathogenic organisms (usually microbes) living in or on the body and so causing harm (e.g. cold, TB, AIDS).
- **Dietary Deficiency Diseases** are caused by a lack of specific nutrients in the diet, e.g. kwashiorkor (protein), scurvy (vitamin C), rickets (vitamin D).
- **Environmental Diseases** are caused by non-living factors in the environment. They include skin cancer (caused by radiation), lung cancer (caused by smoking), asthma (caused by dust), pulmonary fibrosis (caused by dust or pollution), and Creutzfeldt-Jakob disease (caused by prions).
- **Social Diseases** are caused by human activities and lifestyle. They include alcoholism, emphysema, coronary heart disease, anorexia, drug addiction and even accidents.
- **Ageing Diseases** are caused by degeneration of body tissues and include arthritis, arteriosclerosis and cataracts.
- **Genetic Diseases** are caused by genes inherited from parents. These are really characteristics that are unusual in the population and are life-threatening (e.g. muscular dystrophy, cystic fibrosis, haemophilia). In fact all diseases are affected by genetics, but these "single gene disorders" are governed entirely by the action of a single allele and are not influenced by any other factor.

Infectious Disease

To most people "disease" means an infectious disease, and these are the diseases you can "catch". Infectious diseases are caused by a variety of pathogens, including viruses, bacteria, fungi and protoctists. A few of the common pathogens are shown in this table:

	Disease	Pathogen
Viral Diseases	common cold	Rhinovirus
	influenza	Myovirus
	measles	Paramyxovirus
	mumps	paramyxovirus
	chickenpox	Varicella zoster virus
	AIDS	HIV
Bacterial Diseases	tuberculosis	<i>Mycobacterium tuberculosis</i>
	typhoid	<i>Salmonella typhi</i>
	cholera	<i>Vibrio cholerae</i>
	tetanus	<i>Clostridium tetani</i>
	whooping cough	<i>Bordetella pertussis</i>
	pneumonia	<i>Streptococcus pneumoniae</i>
Fungal Diseases	thrush	<i>Candida albicans</i>
	athletes foot	<i>Tinea pedis</i>
	ringworm	<i>Tinea capitis</i>
Protoctist Diseases	malaria	<i>Plasmodium vivax</i>
	amoebic dysentery	<i>Entamoeba histolytica</i>
	sleeping sickness	<i>Trypanosoma spp.</i>

Some pathogens are more harmful than others; in other words they have a greater pathogenicity or virulence. For a pathogen to cause a disease these steps must take place:

1. The pathogen must be transmitted to the human host. Pathogens can be transmitted through drinking water, eating food, breathing aerosol droplets, animal bites, or direct contact.
2. The pathogen must gain entry inside the human body. The human body is protected by a tough layer of skin, but pathogens can enter via cuts in the skin (e.g. rabies, malaria); or the thinner interfaces, such as the digestive system (e.g. cholera, typhoid); gas exchange system (e.g. influenza, tuberculosis) or reproductive system (e.g. AIDS).
3. The pathogen must evade the defences of the host. Humans have a range of defences, such as stomach acid, lysozyme enzymes and the immune system, and these defences are usually very effective at preventing disease. But it only takes a few pathogen cells resisting the defences to multiply and cause a disease.
4. The pathogen must harm the host. Pathogens harm their hosts in two ways. First, by reproducing inside host cells, using up cellular resources and preventing the cell from carrying out its normal reactions. The microbes then usually burst out of the host cell, rupturing the cell membrane and killing the cell in the process. Second, by producing toxins – chemicals that interfere with the body's reactions. These chemicals may inhibit enzymes, bind to receptors, bind to DNA causing mutations, interfere with synapses and so on.

Lifestyle and Disease

A person's lifestyle affects their chances of suffering from any of the diseases listed on the previous page, except the single gene disorders. Lifestyle factors can include diet, exercise, work environment, sexual habits, smoking, drinking and drug-taking. Some of these factors have obvious association with disease (like smoking), while others are less obvious (like occupation), but all the factors have an associated risk.

Risk can be defined as the product of two elements:

$$\text{risk} = \text{probability of event} \times \text{impact of event}$$

For example, there is a high probability of catching a cold, but its impact is pretty minor, so we view catching a cold as a low risk. But smoking 20 cigarettes a day gives a high probability of developing lung cancer and emphysema, which are unpleasant and fatal conditions, so the risk of smoking is high. Risk is often given as a relative risk, i.e. compared to those who have not taken the risk. For example smokers are 15 times more likely to develop lung cancer than non-smokers.

Different disease have specific risk factors, i.e. factors that specifically increase the risk of getting that disease. A few examples are:

- For lung cancer the main risk factors are smoking and cleanliness of the environment.
- For skin cancer the main risk factors are exposure to sunlight and colour of skin.
- For coronary heart disease the main risk factors are diet, age, genetics and exercise.
- For diabetes the main risk factors are genetics, diet and exercise.
- For AIDs the main risk factors are sexual habits, drug habits and genetics.

Some of these risk factors are beyond our control, e.g. genes and age. But the others are lifestyle factors and so within our power to change.

Identifying Risk Factors

How do we know what risk factors are associated with a disease? By epidemiological studies. Epidemiology is the study of the incidence, distribution and associations of diseases with a view to identifying their causes and so effect their prevention.

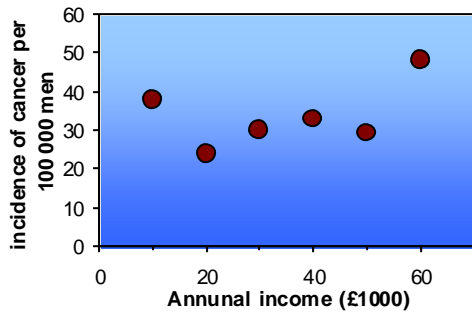

The first step is to look for a correlation (or association) between the incidence of the disease and some factor. This scatter chart plots the incidence of lung cancer in a sample of several thousand men against their annual income. There is clearly no pattern (and this can be confirmed with a statistical test), so income is not a risk factor.

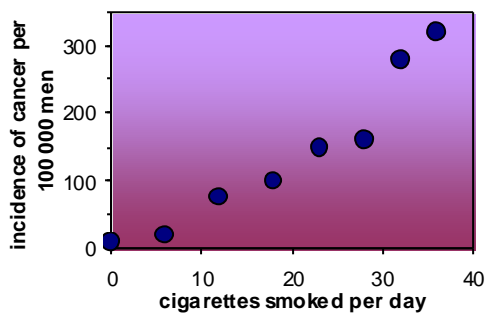

This scatter chart plots the incidence of lung cancer against number of cigarettes smoked. Here there is a correlation: as one variable goes up, so does the other. But this correlation is not evidence that smoking causes lung cancer. The correlation may be coincidence or it may be due to another factor.

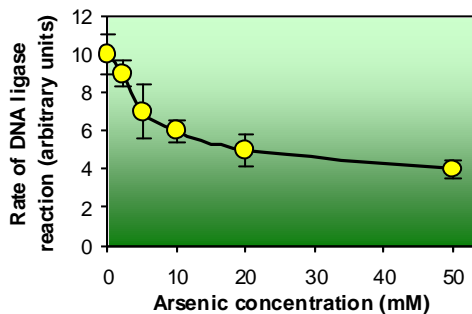

To demonstrate a causal relationship we need to carry out controlled laboratory experiments. This chart shows the effect of arsenic (a component of cigarette smoke) on DNA ligase (an enzyme that repairs DNA). The results show that arsenic inhibits DNA ligase, and in cells that would cause damage to DNA and cancer. So now we have a mechanism to explain the previous correlation, so we have evidence for a causal relationship, and we can say that smoking is a risk factor in lung cancer.

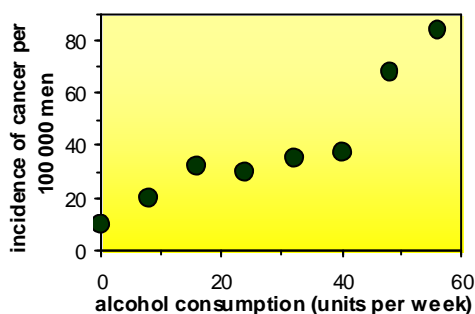

This scatter chart plots the incidence of lung cancer against alcohol consumption. There is a definite correlation, but laboratory studies have failed to show any causal link between alcohol and lung cancer – alcohol is not a risk factor. Instead, the correlation is indirect: heavy drinkers tend also to be heavy smokers and the smoking causes lung cancer.

The Digestive System

Humans, like all animals, use holozoic nutrition, which consists of these stages:

- **ingestion** – taking large pieces of food into the body
- **digestion** – breaking down the food by mechanical and chemical means
- **absorption** – taking up the soluble digestion products into the body's cells
- **assimilation** – using the absorbed materials
- **egestion** – eliminating the undigested material. (Do not confuse egestion, which is the elimination of material from a body cavity, with excretion, which is the elimination of waste material produced from within the body's cells.)

Parts of the Digestive System

The human digestive system comprises a long tube, the alimentary canal or digestive tract (or simply gut) which extends from the mouth to the anus, together with a number of associated glands: the salivary glands, the pancreas and the liver.

1. Mouth (Buccal cavity). The teeth and tongue physically break up the food into small pieces with a larger surface area, and form it into a ball or bolus. The salivary glands secrete saliva, which contains water to dissolve soluble substances, mucus for lubrication, lysozymes to kill bacteria and salivary amylase to digest starch. The food bolus is swallowed by an involuntary reflex action through the pharynx (the back of the mouth). During swallowing the trachea is blocked off by the epiglottis to stop food entering the lungs.

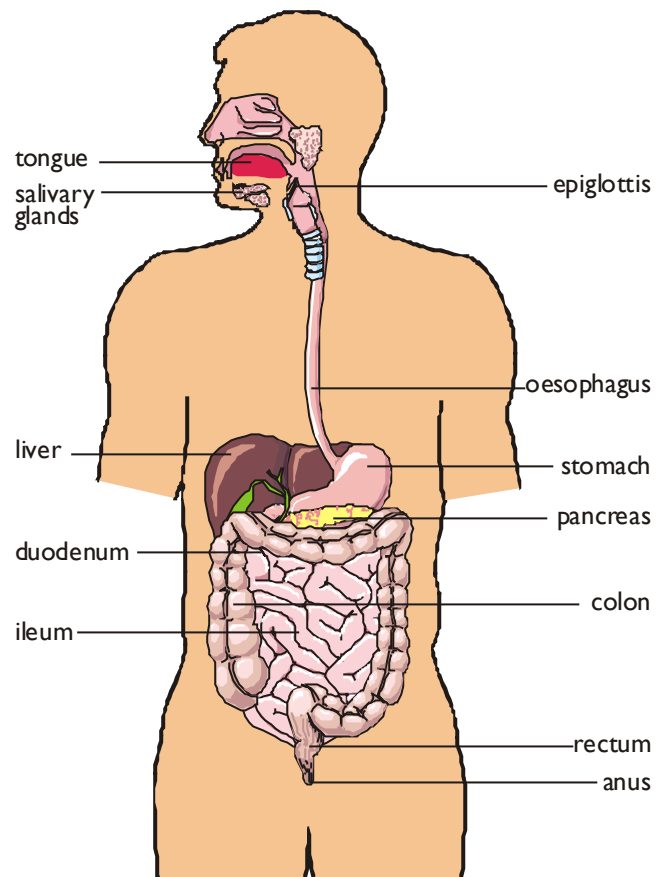

2. Oesophagus (gullet). This is a simple tube through the thorax, which connects the mouth to the rest of the gut. No digestion takes place here. The oesophagus is a soft tube that can be closed, unlike the trachea, which is a hard tube, held open by rings of cartilage. The oesophagus

wall is composed mainly of two layers of muscle: circular muscle (which squeezes the gut when it contracts) and longitudinal muscle (which shortens the gut when it contracts). These two muscles therefore have opposite effects and so are antagonistic. The combination of these two muscles allows food to be pushed along the oesophagus by peristalsis. This is a wave of circular muscle contraction, which passes down the gut and is completely involuntary:

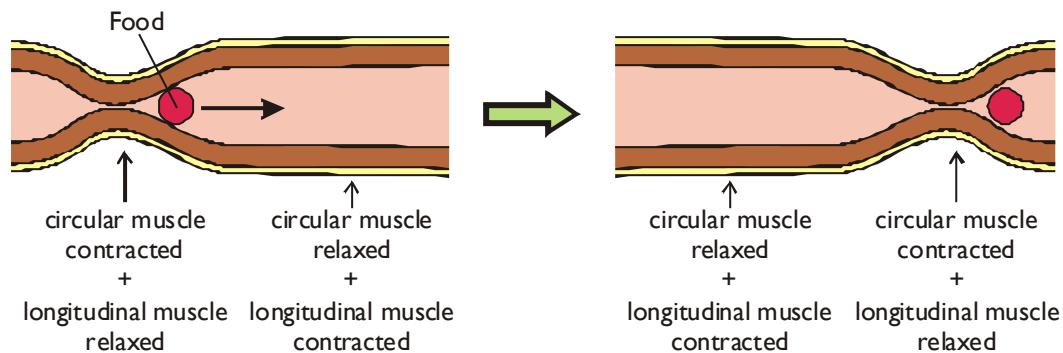

3. Stomach. This is an expandable bag where the food is stored for up to a few hours. There are three layers of muscle to churn the food into a liquid called chyme. This is gradually released into the small intestine by a sphincter, a region of thick circular muscle that acts as a valve. The cells of the stomach wall secrete a solution containing: hydrochloric acid (pH 1) to kill bacteria (the acid does not help digestion, in fact it hinders it by denaturing most enzymes); mucus to lubricate the food and to line the epithelium to protect it from the acid; and some protease enzymes. No other digestion takes place in the stomach.

4. Small Intestine. The first 30cm of the small intestine is called the duodenum. Although this is short, almost all the digestion takes place here, due to two secretions: pancreatic juice and bile. Pancreatic juice is secreted by the pancreas into the duodenum through the pancreatic duct. It contains numerous amylase, protease and lipase enzymes. Bile is secreted by the liver, stored in the gall bladder, and released into the duodenum through the bile duct. Bile doesn't contain any enzymes, but it does contain bile salts to aid lipid digestion, and the alkali sodium hydrogen carbonate to neutralise the stomach acid. This give chyme in the duodenum a pH of around 7.5, so the pancreatic enzymes can work at their optimum pH.

The rest of the small intestine is called the ileum. This is the site of final digestion and absorption. To maximise the rate of absorption the ileum has the three features dictated by Fick's law:

- The ileum has a huge surface area. It is over 6m long; the internal surface has large and small folds (villi); and the epithelial cells lining the ileum have microvilli. Don't confuse these two: villi are large structures composed of hundreds of cells that can easily be seen

with a light microscope, while microvilli are small sub-cellular structures formed by the folding of the plasma membrane of individual epithelial cells. Microvilli can only be seen clearly with an electron microscope, and appear as a fuzzy brush border under the light microscope. The total internal surface area of the ileum is over 2000m².

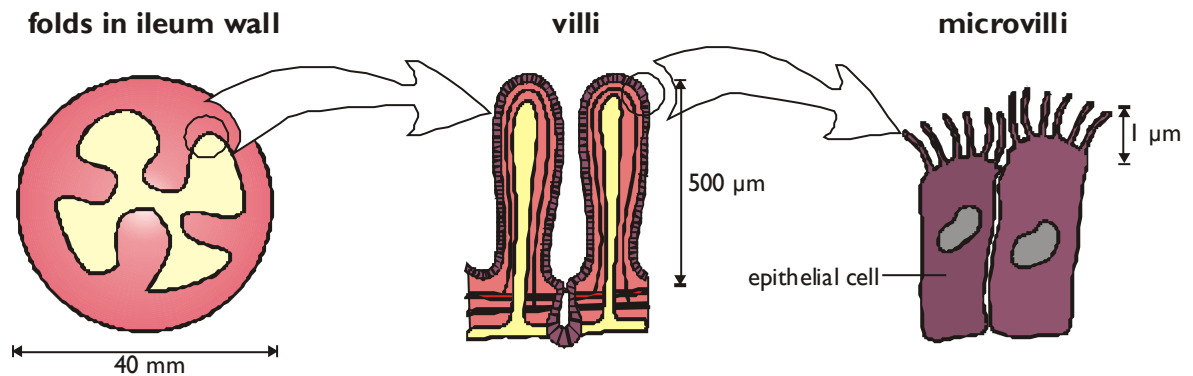

- There is a short diffusion distance. Between the lumen of the gut and the blood there is just a single layer of epithelial cells and the single-celled wall of the capillaries.
- A high concentration gradient is maintained by mixing the fluids on either side of the exchange surface. On the lumen side, the circular and longitudinal muscles propel the chyme by peristalsis, and mix the contents by pendular movements (bi-directional peristalsis). The microvilli can also wave to stir the contents near the epithelial cells. On the blood side, the blood flow ensures there is always a low concentration of nutrients.

The layer of cells that line the ileum are called the epithelium, and the epithelial cells are highly specialised for their role. They contain microvilli; membrane proteins for facilitated diffusion and active transport; mitochondria; and membrane-bound enzymes.

5. Large Intestine. The large intestine comprises the caecum, appendix, colon and rectum. Food can spend 36 hours in the large intestine, while water is absorbed to form semi-solid faeces. Faeces is made up of plant fibre (cellulose mainly), cholesterol, bile, mucus, mucosa cells (250 g of cells are lost each day), bacteria and water, and is released by the anal sphincter. This is a rare example of an involuntary muscle that we can learn to control (during potty training).

Digestion of carbohydrates

By far the most abundant carbohydrate in the human diet is starch (in bread, potatoes, cereal, rice, pasta, biscuits, cake, etc), but there may also be a lot of sugar (mainly sucrose) and some glycogen (in meat). Starch is digested to glucose in two stages:



1. **Salivary amylase** starts the digestion of starch in the mouth. Very little digestion actually takes place, since amylase is quickly denatured in the stomach, but it does help to clean the mouth of starch and reduce bacterial infection.
2. **Pancreatic amylase** digests all the remaining starch in the duodenum. Amylase digests starch molecules from the ends of the chains in two-glucose units, forming the disaccharide maltose. Glycogen is also digested here.
3. **Disaccharidases** in the membrane of the ileum epithelial cells complete the digestion of disaccharides to monosaccharides. This includes maltose from starch digestion as well as any sucrose and lactose in the diet. There are three important disaccharidase enzymes:

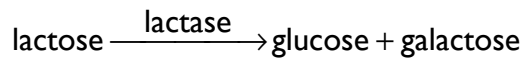
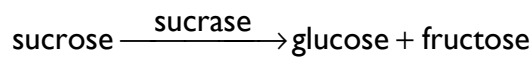
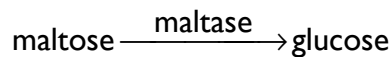

The disaccharidase enzymes are unusual in that they are located in the membrane of the ileum epithelial cells.

Absorption of Monosaccharides

The monosaccharides (glucose, fructose and galactose) are absorbed by coupled active transport into the epithelial cells of the ileum, as shown in this diagram:

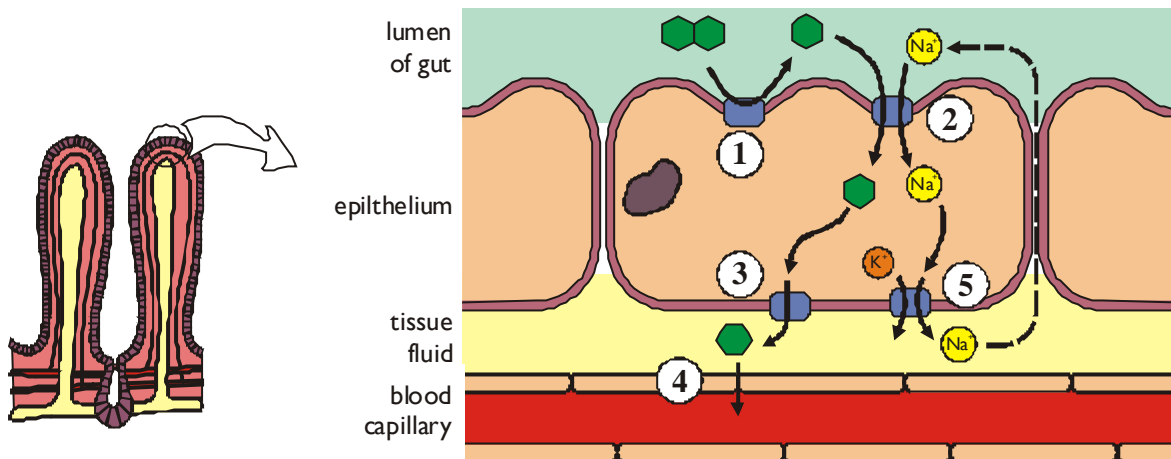

1. The membrane-bound disaccharidase enzymes hydrolyse the disaccharides into monosaccharides.
2. The sodium/glucose cotransporter carries glucose (and other hexose sugars) into the epithelial cell, up their concentration gradient.
3. The glucose diffuses through the epithelial cell and leaves the cell by facilitated diffusion through a glucose carrier protein.

4. The glucose enters the blood capillary by diffusing through gaps between the cells in the capillary wall.
5. Sodium ions are actively transported out of the cell by the Na/K pump into the tissue fluid, from where they can diffuse into the blood or back into the lumen. the epithelial cell

Active transport requires energy in the form of ATP, but it allows very rapid absorption, even up a concentration gradient. The carbohydrates that make up plant fibres (cellulose, hemicellulose, lignin, etc) cannot be digested, so pass through the digestive system as fibre and are egested.

Lactose Intolerance

Some people can't eat food containing milk because it makes them ill, with symptoms including flatulence and explosive diarrhoea. This happens because they don't have a lactase enzyme, so they can't digest lactose. Since lactose can't be absorbed it passes through to the large intestine, where it is fermented by the bacteria in the colon, who produce acids and gases like methane and carbon dioxide. The gases cause flatulence and the other products cause diarrhoea by lowering the water potential of the colon so causing less water to be absorbed.

In fact most humans (and all other adult mammals) are lactose intolerant, and this is the "normal" state. Lactose is only found in milk, which is produced by the mammary glands of female mammals to feed their young. Baby mammals all make lactase in order to digest the lactose in milk, but when they are weaned (eat solid food) they stop drinking milk and the gene for lactase production is switched off. Humans are unique in that, in some human societies, adults drink animal milk. These humans generally have a mutation that causes lactase to be produced throughout life, so these people are lactose tolerant and can drink milk without any ill effects.

Cholera and Diarrhoea

Cholera is an infectious disease caused by the bacterium *Vibrio cholerae*. *V.cholerae* is a typical prokaryotic cell with a slightly curved rod shape and a single flagellum (right). The symptoms of cholera include stomach cramps, vomiting, fever and severe diarrhoea. In severe cases up to 20 litres of water can be lost per day, and if untreated, leads to death in 75% of cholera patients. There were several serious



outbreaks of cholera in the UK in the 19th century and cholera remains a major killer of small children in developing countries (several million deaths each year). However cholera can be treated simply and cheaply.

How *V.cholerae* causes Diarrhoea

1. The cholera bacterium adheres to the epithelium and secretes the cholera toxin CT. CT enters the epithelial cells and activates a chloride ion channel in the cell membrane.
2. This causes chloride ions to diffuse out of the cells into the lumen.
3. This lowers the water potential in the lumen of the gut.
4. So water is lost from cells to the lumen by osmosis, producing diarrhoea and dehydration.

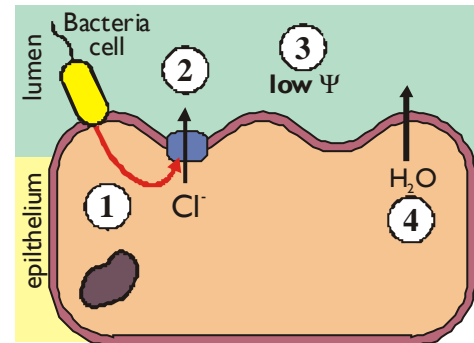

Treatment for Diarrhoea

The treatment for diarrhoea was revolutionised in the 1960s, with the development of oral rehydration therapy (ORT). This simple and cheap treatment consists of drinking an oral rehydration solution (ORS) of glucose and salt (NaCl), and sometimes other ions like potassium and bicarbonate. ORT makes use of the sodium/glucose cotransporter protein that normally absorbs glucose into the ileum epithelial cells.

1. If both Na⁺ and glucose are present in the lumen, they bind to the sodium-glucose co-transporter protein. Transport only works if both molecules are present, which is why salt alone is not an effective treatment. ORS contain equimolar concentrations of glucose and salt.
2. The transporter protein carries the Na⁺ and glucose into the cell, down their concentration gradients.
3. This lowers the water potential inside the epithelial cells.
4. So water diffuses from the lumen into the epithelial cells by osmosis, rehydrating cells and reducing diarrhoea.

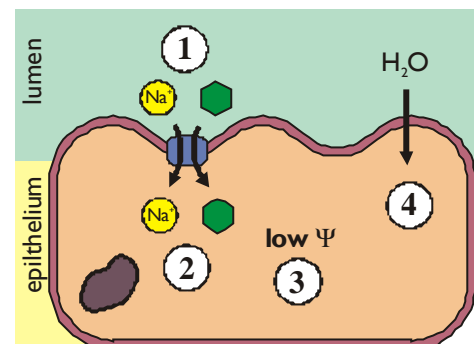

The Gas Exchange System

This diagram shows the gas exchange system in humans:

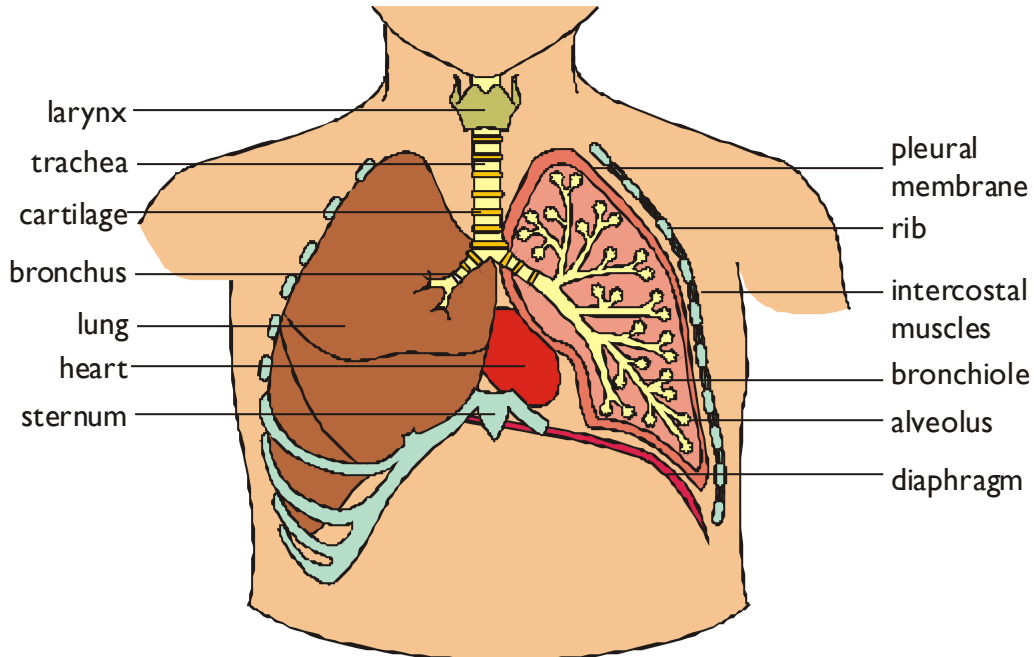

The gas exchange system is also referred to as the respiratory system, but this can be confusing as respiration takes place in all cells, and is quite distinct from gas exchange. The actual gas exchange surface is on the alveoli inside the lungs. This surface meets the three requirements of Fick's law:

- A large surface area. Although each alveolus is tiny, an average adult has about 600 million alveoli, giving a total surface area of about 100m², so the area is huge.
- A small distance between the source and the destination. The walls of the alveoli are composed of a single layer of flattened epithelial cells, as are the walls of the capillaries, so gases need to diffuse through just two thin cells.

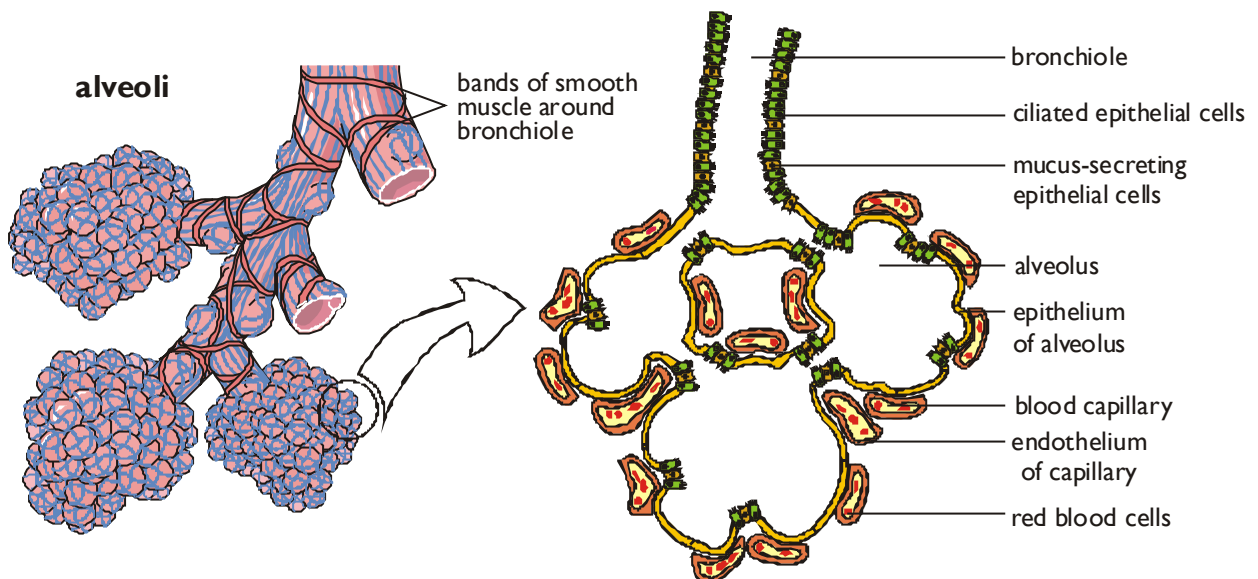

- A mechanism to maintain a high concentration gradient across the gas exchange surface. The steep concentration gradient across the gas exchange surface is maintained in two ways: by blood flow on one side and ventilation on the other side. This means oxygen can always diffuse down its concentration gradient from the air to the blood, while at the same time carbon dioxide can diffuse down its concentration gradient from the blood to the air

The large surface area and short distance that are ideal for gas exchange also cause a problem: water loss. Water inevitably diffuses down its concentration gradient from the tissue fluid and alveoli cells into the air in the alveoli, so the air in the alveoli is constantly moist. This is why exhaled air contains more water than normal, inhaled air, and this represents a significant loss of water from the body. However, by having the gas exchange surface deep inside the body at the end of long narrow bronchioles, the water loss is minimised. The moist alveolar air means that there is less of a diffusion gradient (and so less water is lost) than if the alveoli were exposed to outside dry air. The epithelial cells secrete a soapy surfactant to reduce the surface tension of the water (due to hydrogen bonds) and make it less "sticky". Without this surfactant the alveoli would collapse, and this can be a problem in premature babies.

Some of the epithelial cells of the bronchioles secrete mucus, which traps bacteria and other microscopic particles that enter the lungs. This mucus is constantly swept upwards by the cilia of the ciliated epithelial cells to the throat, where it is swallowed and any bacteria in it are killed by the acid in the stomach. Phagocyte cells migrate from the blood capillaries to the alveolar air space to kill any bacteria that have not been trapped by the mucus.

Ventilation

Ventilation means the movement of air over the gas exchange surface (also known as breathing). Lungs are not muscular and cannot ventilate themselves, but instead the whole thorax moves and changes size, due to the action of two sets of muscles: the intercostal muscles and the diaphragm. These movements are transmitted to the lungs via the pleural sac surrounding each lung. The outer membrane is attached to the thorax and the inner membrane is attached to the lungs. Between the membranes is the pleural fluid, which is incompressible, so if the thorax moves, the lungs move too. The alveoli are elastic and collapse if not held stretched by the thorax.

The muscle contractions change the volume of the thorax, which in turn changes the pressure in the lungs (by Boyle's law), which in turn causes air to move. Ventilation in humans is tidal, which

means the air flows in and out by the same route. The rule is that *air always flows from a high pressure to a low pressure*. These volume and pressure changes are shown in this graph:

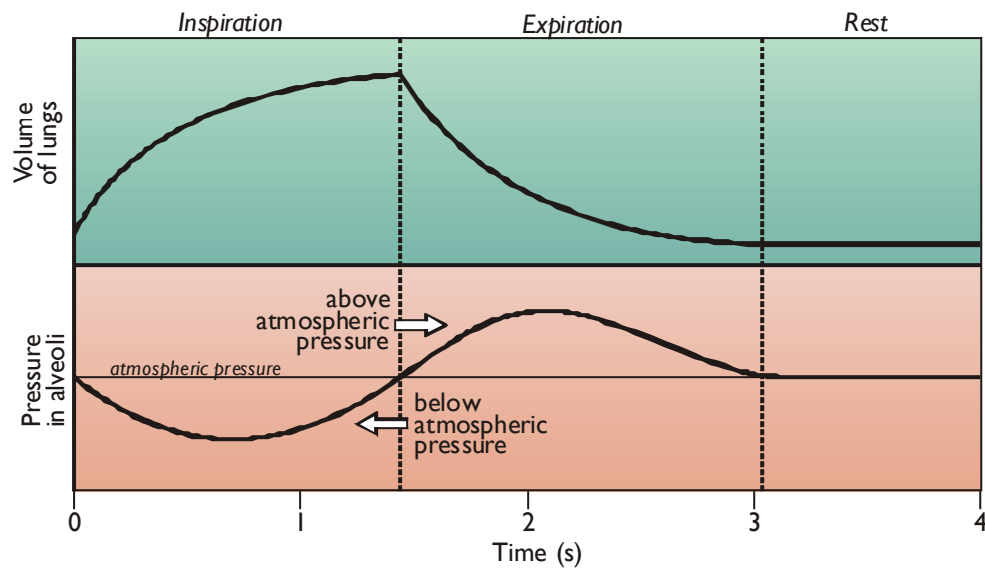

Inspiration

1. The diaphragm contracts and flattens downwards and the external intercostal muscles contract, pulling the ribs up and out.
2. This increases the volume of the thorax and the lungs, and stretches the elastic-walled alveoli.
3. This decreases the pressure of air in the alveoli below atmospheric.
4. Air flows in from high pressure to low pressure.

Normal expiration

1. The diaphragm relaxes and curves upwards and the external intercostal muscles relax, allowing the ribs to fall.
2. This decreases the volume of the thorax and the lungs, and allows the alveoli and bronchioles to shrink by elastic recoil.
3. This increases the pressure of air in the alveoli above atmospheric.
4. Air flows out from high pressure to low pressure.

Forced expiration

1. The abdominal muscles contract, pushing the diaphragm upwards
2. The internal intercostal muscles contract, pulling the ribs downward
3. This gives a larger and faster expiration, used in exercise

The breathing rate can be calculated from this graph by measuring the time taken for one breathing cycle and using the formula:

$$\text{breathing rate (breaths per minute)} = \frac{60}{\text{cycle time (s)}}$$

The first breath

In the uterus the lungs of a fetus are largely collapsed and filled with amniotic fluid. Very soon after birth the baby takes its first breath by contracting its diaphragm with a force 20 times usual. This stretches the alveoli and fills the lungs with air. The alveoli then remain stretched throughout life.

Ventilation and exercise

Both the rate and depth (tidal volume) of breathing can be varied by the body. The product of these two is called the Pulmonary Ventilation – the volume air ventilating the lungs each minute:

$$\text{pulmonary ventilation} = \text{ventilation rate} \times \text{tidal volume}$$

	ventilation rate (breaths min ⁻¹)	tidal volume (cm ³ breath ⁻¹)	pulmonary ventilation (cm ³ min ⁻¹)
at rest	12	500	6 000
at exercise	18	1 000	18 000

When the body exercises the ventilation rate and depth increases so that

- Oxygen can diffuse from the air to the blood faster
- Carbon dioxide can diffuse from the blood to the air faster

These changes allow aerobic respiration in muscle cells to continue for longer.

Lung Diseases

The features of the lungs that make them so good at gas exchange also makes them susceptible to disease. The large volumes of air passing through the lungs may carry infectious pathogens or other microscopic particles that cause disease. We shall look at four diseases of the lungs: Tuberculosis; asthma; fibrosis and emphysema.

Pulmonary Tuberculosis

Pulmonary Tuberculosis (or TB) is an infectious disease caused by the bacterium *Mycobacterium tuberculosis*. In 19th-century England one in five died of TB, and although the disease has been almost eradicated in the developed world, it is still a major killer in the developing nations, responsible for 1.5 million deaths in 2006. The symptoms are a persistent cough with chest pains, tiredness, a loss of appetite and weight loss, and in serious cases coughing up blood, wasting away and death.

TB is transmitted by aerosol droplets from coughs and sneezes of infected persons. Infection is most likely to result from prolonged exposure, such as in crowded slums or hospitals.

- The bacterial cells are breathed in and invade the epithelial cells of the alveoli and bronchioles.
- Here they multiply to form lumps called tubercles, in which the bacteria remain alive but dormant.
- The tubercles stimulate an inflammatory response by the white blood cells of the immune system, resulting scar tissue that can be seen in a chest X-ray.
- After a delay of months to years the bacteria emerge from the tubercles and start multiplying inside the lung epithelial cells, killing them.
- This destroys the alveoli, so making gas exchange difficult and causing the persistent cough.
- The TB bacteria can also spread through the bloodstream to other organs, like the kidney, bone and nervous tissue, which are destroyed as well. This causes weakness as the body wastes away and the bacteria appear to “consume” the body – hence the old name for TB: consumption.

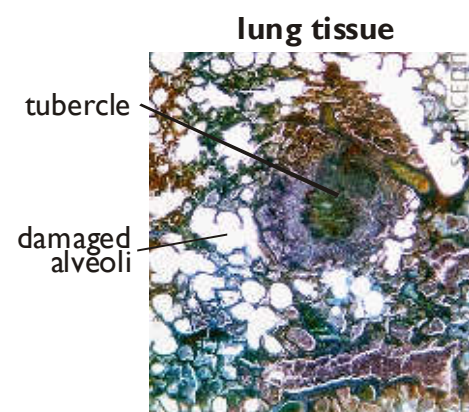
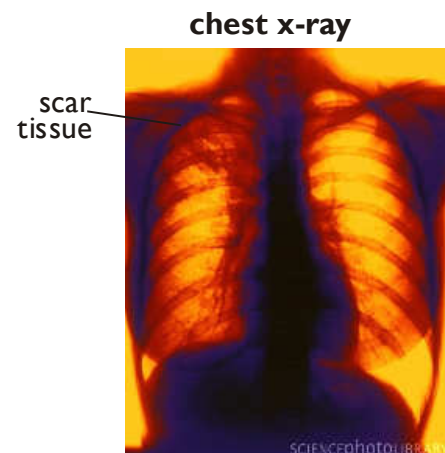

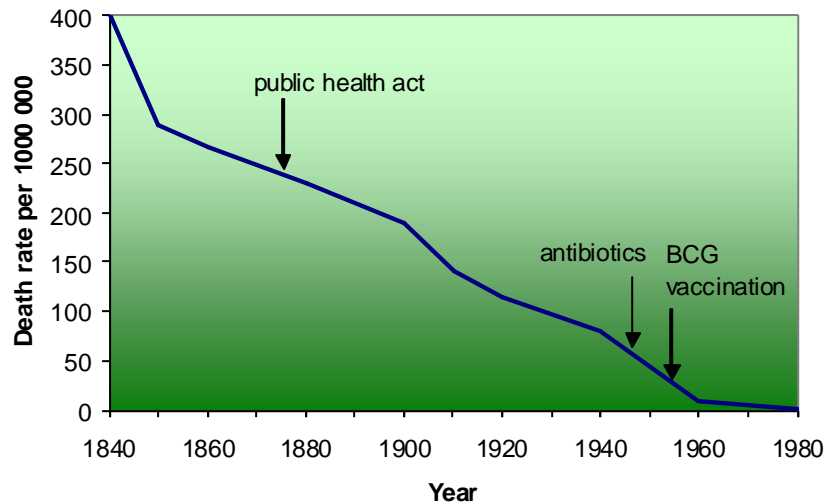

As this graph shows, the death rate from TB in the UK has steadily declined over the last 150 years. This decline is due to a combination of reasons:

- Improved housing and hygiene. TB spreads most rapidly in crowded, slum conditions.
- Improved diet. The immune system works less well with an unbalanced diet.
- Pasteurisation of milk and improved animal husbandry. Before this, transmission of TB from cows was common.
- Antibiotics. As a bacterial disease, TB can be treated by antibiotics. The most effective antibiotic was streptomycin, but now some *M. tuberculosis* bacteria have developed resistance to streptomycin, so usually a cocktail of four different antibiotics have to be used for several months.
- Vaccination. TB can also be prevented by the BCG vaccine. This vaccine is named after the two Frenchmen (Calmette and Guerin) who developed it at the Pasteur Institute in Paris in 1921. The BCG vaccine contains a live but weak strain of *M. bovis*, a similar bacterium that causes TB in cattle.

Unfortunately, the incidence of TB is currently rising due to resistance of the bacterium to the BCG vaccine and to the increase in AIDs.

Asthma

Asthma is an allergic response that causes difficulty breathing, wheezing, tight chest and coughing. It is thought to affect 10% of the world's population and is responsible for 2000 deaths per year in the UK.

Asthma is not an infectious disease, but is caused by physical factors called allergens in the environment. These allergens include pollen, faeces of dust mites and animal fur. Other factors that

can contribute to asthma include polluting gases like sulphur dioxide, exercise, cold weather, infection and stress.

- These allergens trigger an inflammatory response by the immune system. White blood cells called mast cells release histamines, which cause the smooth circular muscles of the bronchioles to contract, narrowing the airways - bronchoconstriction.
- The epithelial cells also secrete more mucus, which further blocks the airways.
- The constricted bronchioles slows ventilation, thus reducing gas exchange in the alveoli and cellular respiration throughout the body.
- The constricted bronchioles also cause the breathing difficulties, wheezing and coughing, as the lungs try to loosen the mucus.

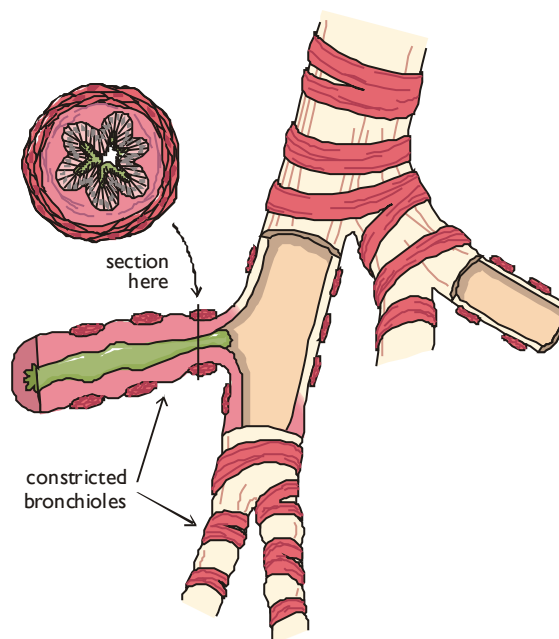

Asthma can be treated by inhaling drugs that relax the smooth muscles and by anti-inflammatory drugs.

Pulmonary Fibrosis

Pulmonary fibrosis is a severe shortness of breath caused by inhalation of fine dust particles or chemicals. The particles stimulate an inflammatory response in the lungs, which results in the growth of fibrous scar tissue around the alveoli. This scar tissue reduces the elasticity of the alveoli and compresses them, reducing air flow and gas exchange. There are hundreds of different causes of pulmonary fibrosis, and since these are usually found in work-place environments, pulmonary fibrosis is known as an occupational disease. Some of the main causes are shown in this table:

Disease	Cause	Risk occupation
pneumoconiosis	coal dust	coal mining
asbestosis	asbestos	demolition workers
silicosis	silica dust	quarrying, mining
berylliosis	beryllium	electronics, nuclear power industries
farmer's lung	mould spores in hay	farming
bird fancier's lung	proteins in bird faeces	bird breeders, poultry farmers
ventilator pneumonitis	mould spores	air conditioning and heating workers

Emphysema

Emphysema is a lung disease characterised by severe breathing difficulties resulting in an inability to do any exercise. It caused almost exclusively by smoking and 20% of all smokers suffer from emphysema; 10% of absence from work in the UK is due to emphysema and it kills 20 000 per year in the UK.

The tar in cigarette smoke stimulates the white blood cells to release protease enzymes in the lungs. These protease enzymes digest the proteins forming the elastic tissue in the epithelial cells of the alveoli, so the alveoli can't expand and recoil, making ventilation difficult. In severe cases the epithelial cells are destroyed completely, so alveoli merge to form large air sacs with a much smaller surface area. These all reduce the rate of gas exchange, so reducing cellular respiration and making any muscular activity very difficult.

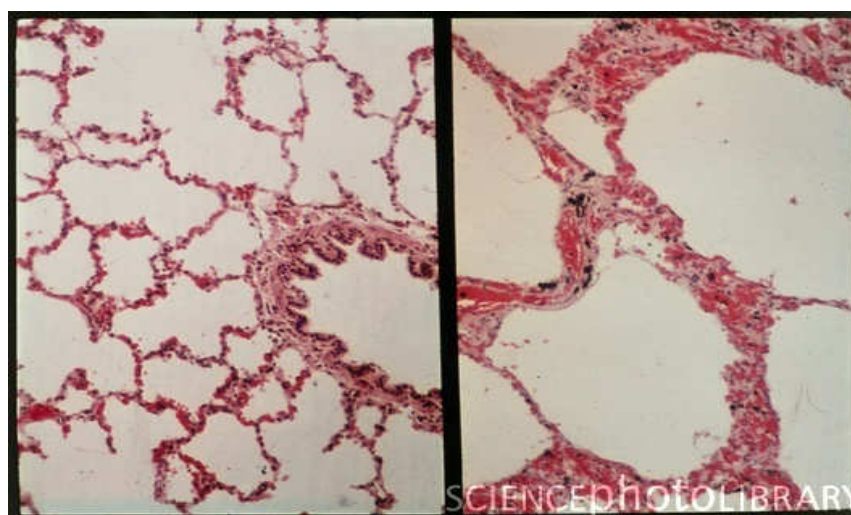

normal alveoli

alveoli with emphysema

Emphysema is incurable, though giving up smoking prevents the symptoms getting any worse. Breathing pure oxygen compensates for the poor efficiency of gas exchange, so allowing more respiration.

The four lung diseases are compared in this table.

Disease	Cause	Symptoms	Effects	Risk Factors
TB	bacterial infection	chest pain, coughing blood, fever, death	bacteria form tubercles in lungs then reproduce and consume tissues.	overcrowding, poor diet, AIDs
Asthma	allergens	temporary breathing difficulties; wheezing	bronchiole muscles contract, excess mucus	pollen, dust, SO ₂ , cold air.
Pulmonary fibrosis	dust	breathing difficulty	fibrous tissue	coal dust, silica dust, mould spores.
emphysema	smoking	permanent breathing difficulty	elastic tissue digested	smoking

The Circulatory System

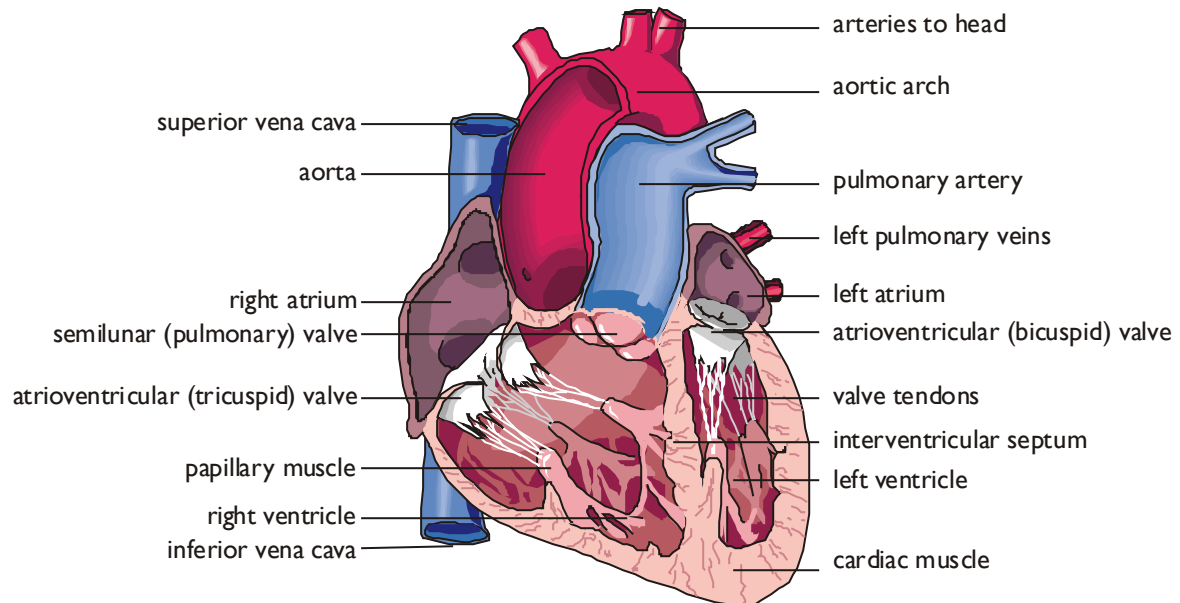

The human heart has four chambers: two thin-walled atria on top, which receive blood, and two thick-walled ventricles underneath, which pump blood. Veins carry blood into the atria and arteries carry blood away from the ventricles. Between the atria and the ventricles are atrioventricular valves, which prevent back-flow of blood from the ventricles to the atria. The left valve has two flaps and is called the bicuspid (or mitral) valve, while the right valve has 3 flaps and is called the tricuspid valve. The valves are held in place by valve tendons (“heart strings”) attached to papillary muscles, which contract at the same time as the ventricles, holding the valves closed. There are also two semi-lunar valves in the arteries (the only examples of valves in arteries) called the pulmonary and aortic valves.

The left and right halves of the heart are separated by the inter-ventricular septum. The walls of the right ventricle are 3 times thinner than on the left and it produces less force and pressure in the blood. This is partly because the blood has less far to go (the lungs are right next to the heart), but also because a lower pressure in the pulmonary circulation means that less fluid passes from the capillaries to the alveoli. The internal volume of the left and right ventricles is the same.

The heart is made of cardiac muscle, composed of cells called myocytes. When myocytes receive an electrical impulse they contract together, causing a heartbeat. Since myocytes are constantly active, they have a great requirement for oxygen, so are fed by numerous capillaries from two coronary arteries. These arise from the aorta as it leaves the heart. Blood returns via the coronary sinus, which drains directly into the right atrium.

The Cardiac Cycle

When the cardiac muscle contracts the volume in the chamber decreases, so the pressure in the chamber increases, so the blood is forced out. Cardiac muscle contracts about 75 times per minute, pumping around 75 cm³ of blood from each ventricle each beat (the stroke volume). It does this continuously for up to 100 years.

Cardiac muscle is myogenic, which means that it can contract on its own, without needing nerve impulses. Contractions are initiated within the heart by the sino-atrial node (SAN, or pacemaker) in the right atrium. This extraordinary tissue acts as a clock, and contracts spontaneously and rhythmically about once a second, even when surgically removed from the heart.

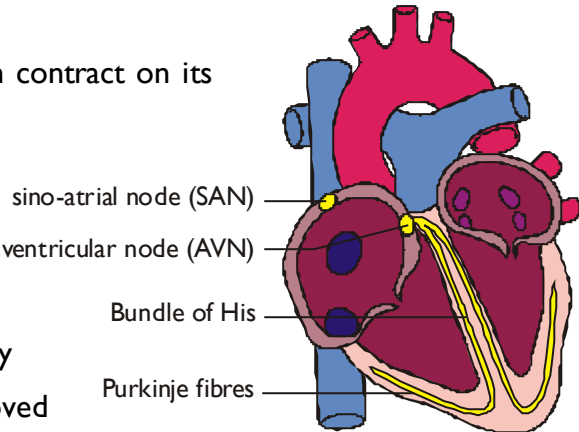

There is a complicated sequence of events at each heartbeat called the cardiac cycle. The cardiac cycle has three stages:

1. **Atrial Systole.** The SAN contracts and transmits electrical impulses throughout the atria, which both contract, pumping blood into the ventricles. The ventricles are electrically insulated from the atria, so they do not contract at this time. The blood can't flow back into the veins because of the valves in the veins.
2. **Ventricular Systole.** The electrical impulse passes to the ventricles via the atrioventricular node (AVN), the bundle of His and the Purkinje fibres. These are specialised fibres that do not contract but pass the electrical impulse to the base of the ventricles, with a short but important delay of about 0.1s. The ventricles therefore contract shortly after the atria, from the bottom up, squeezing blood upwards into the arteries. The blood can't go into the atria because of the atrioventricular valves, which are forced shut with a "lub" sound.
3. **Diastole.** The atria and the ventricles relax, while the atria fill with blood. The semilunar valves in the arteries close as the arterial blood pushes against them, making a "dup" sound.

The events of the three stages are shown in the chart below. The pressure changes show most clearly what is happening in each chamber. Blood flows because of pressure differences, and it **always flows from a high pressure to a low pressure**, if it can. So during atrial systole the atria contract, making the atrium pressure higher than the ventricle pressure, so blood flows from the atrium to the ventricle. The artery pressure is higher still, but blood can't flow from the artery back into the heart due to the semi-lunar valves. The valves are largely passive: they are opened by blood flowing through them the right way and are forced closes when blood tries to flow through them the wrong way. Whenever lines cross in the pressure graph it means that a valve opens or closes.

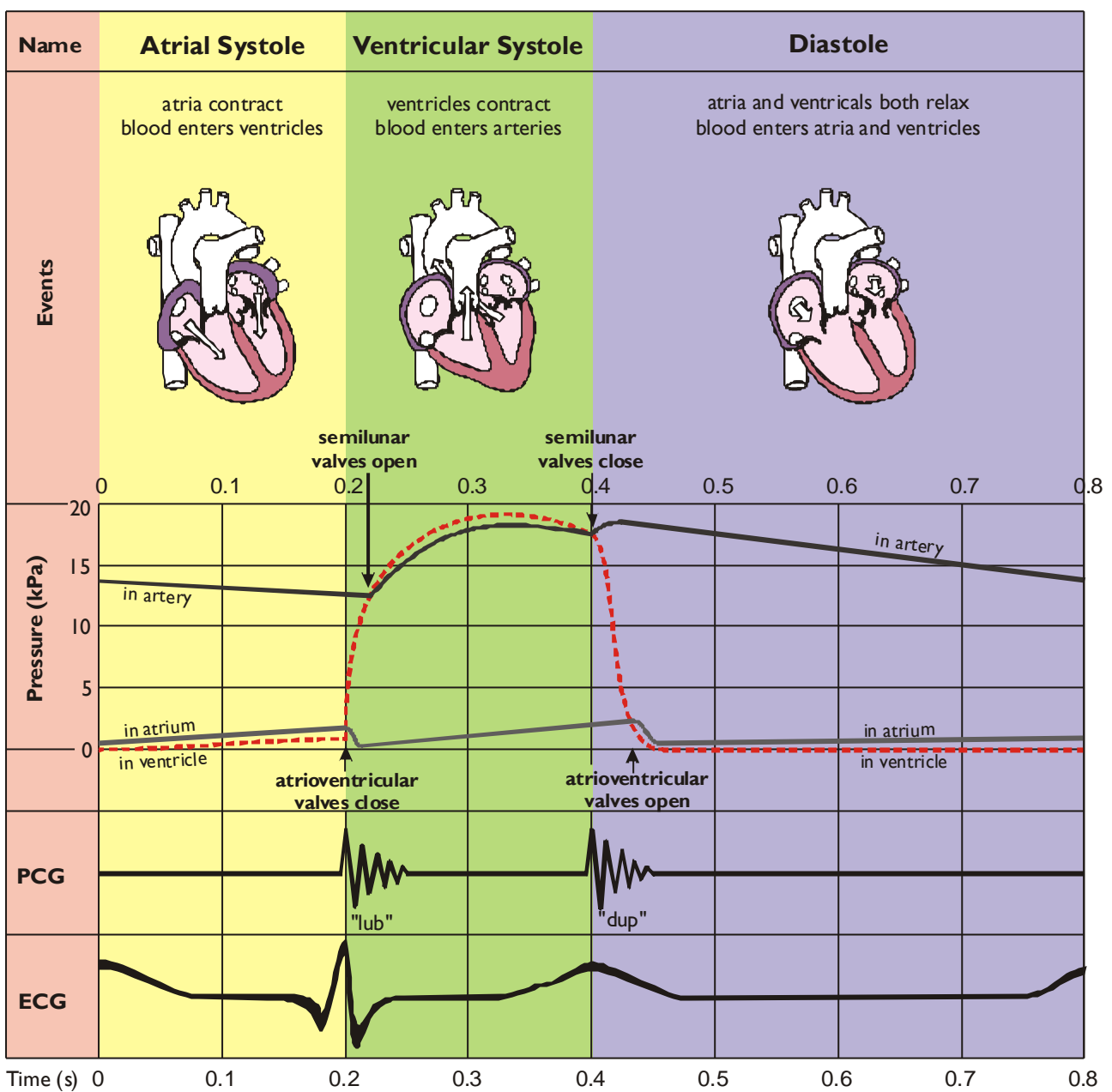

This diagram just shows one side of the heart. The two sides have identical traces except that the pressures in the right side are lower than those in the left side.

The PCG (or phonocardiogram) is a recording of the sounds the heart makes. The cardiac muscle itself is silent and the sounds are made by the valves closing. The first sound (lub) is due to the atrioventricular valves closing and the second (dup) is due to the semi-lunar valves closing.

The ECG (or electrocardiogram) is a recording of the electrical activity of the heart. There are characteristic waves of electrical activity marking each phase of the cardiac cycle. Changes in these ECG waves can be used to help diagnose problems with the heart.

The heart rate can be calculated from this chart by measuring the time taken for one cycle and using the formula:

$$\text{heart rate (beats per minute)} = \frac{60}{\text{cycle time (s)}}$$

Cardiac Output

The rate at which the heart beats and the volume of blood pumped at each beat (the stroke volume) can both be controlled. The product of these two is called the cardiac output – the amount of blood flowing in a given time:

$$\text{cardiac output} = \text{heart rate} \times \text{stroke volume}$$

	heart rate (beats min ⁻¹)	stroke volume (cm ³ beat ⁻¹)	cardiac output (cm ³ min ⁻¹)
at rest	75	75	5 600
at exercise	180	120	22 000

As the table shows, the cardiac output can increase dramatically when the body exercises. There are several benefits from this:

- to get oxygen to the muscles faster
- to get glucose to the muscles faster
- to get carbon dioxide away from the muscles faster
- to get lactate away from the muscles faster
- to get heat away from the muscles faster

Coronary Heart Disease

Coronary heart disease (CHD) is caused by a blockage in the coronary blood system. This is the system that feeds the cardiac muscle cells so that they can respire and contract. Cardiac muscle works constantly throughout life and is incapable of anaerobic respiration, so it has a great demand for oxygen and glucose. There are two coronary arteries that arise directly from the aorta, and these split into numerous smaller arteries (arterioles) and then a network of capillaries, where exchange with the cardiac cells actually takes place. A blockage in a coronary artery can restrict the supply of oxygen to the cardiac cells, killing them and causing a heart attack. The steps are as follows:

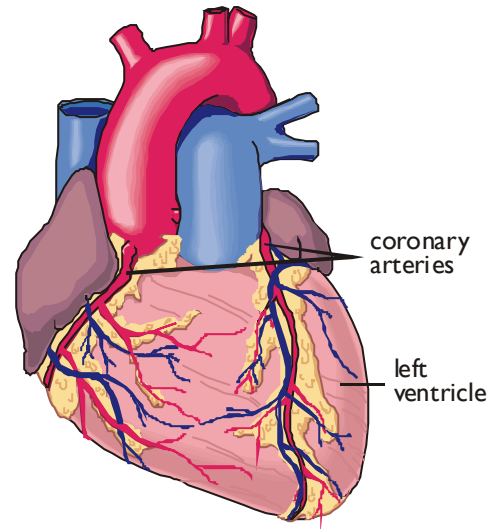

1. Cholesterol and other insoluble lipids collect on the inside of a coronary artery. This deposit is called an atheroma, and it narrows the lumen of the artery, restricting blood flow – atherosclerosis.
2. The atheroma can collect minerals and become hardened to form a rough plaque.
3. The plaque weakens the wall of the artery, so the pressure of blood causes a local swelling called an aneurism. If the wall is particularly weak the aneurism may burst causing blood loss and probable death.
4. The plaque can also encourage the formation of a blood clot called a thrombus. Alternatively, a mobile clot from elsewhere in the blood stream (an embolism) can become lodged in the atheroma. The clot grows until it completely blocks the artery, forming a coronary thrombosis.
5. Any cardiac cells “downstream” of the thrombosis will be starved of oxygen, cannot respire and so die. This is a myocardial infarction, more commonly known as a heart attack. The severity of the heart attack depends on how far along the coronary artery the thrombosis is. If only a small part of one ventricle is killed then the patient will recover, but a thrombosis early in the coronary artery will always be fatal.

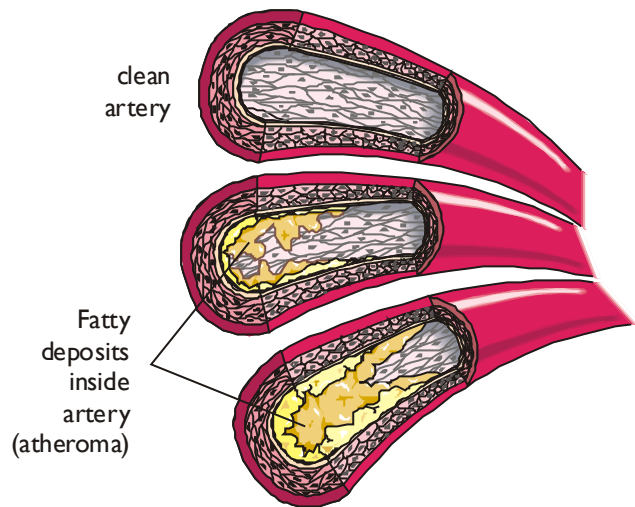

The five stages in a heart attack are summarised in this diagram

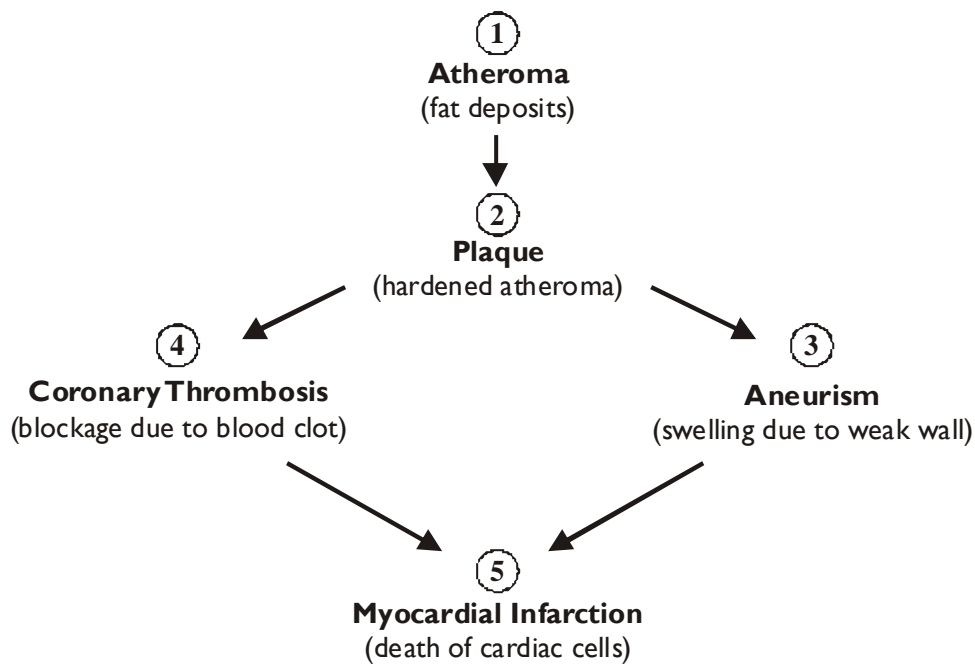

Risk Factors for Coronary Heart Disease

There are a number of risk factors that are associated with coronary heart disease. The more of the factors that apply, the greater the risk of a heart attack. Some of the main factors are:

- **Blood Cholesterol.** Cholesterol in the blood comes from the diet and from the liver, where it is synthesised. Cholesterol is carried in large complexes with proteins, called lipoproteins. High-density lipoproteins (HDLs) remove cholesterol from tissues, so decrease the risk of atheromas, while Low-density lipoproteins (LDLs) deliver cholesterol to tissues, so increase the risk of atheromas.
- **Blood Pressure.** High blood pressure increases the risk of an aneurism and stimulates thickening of artery wall, increasing the risk of thrombosis. Stress, diet and lack of exercise can all increase blood pressure.
- **Genetics.** Both blood pressure and fat metabolism are affected by genes, so genes undoubtedly affect the chance of a coronary thrombosis. This doesn't mean that, for some people, a heart attack is inevitable; it just means some people have to be even more careful about their lifestyle risk factors.
- **Diet.** High levels of saturated fat increase the amount of cholesterol carried in the blood and so increase the risk of atherosclerosis. High levels of salt increase blood pressure and so increase the risk of aneurism. However, fibre and vitamin C reduce the risk of heart disease.
- **Smoking.** Smokers are between two and six times more likely to suffer from coronary heart disease than non-smokers. The carbon monoxide and nicotine in cigarette smoke both cause an increase in blood pressure.

The Immune System

The Immune System is the body's defence system against disease. It consists mainly of the white blood cells, but parts of the immune system are spread all over the body. They include:

- **The lymph and blood vessels.** These transport pathogens and leukocytes all over the body.
- **The lymph nodes.** These contain millions of phagocyte and lymphocyte cells, which identify and remove pathogens from lymph.
- **The spleen.** This contains millions of phagocyte and lymphocyte cells, which identify and remove pathogens from blood.
- **The thymus.** This is where blood stem cells are differentiated into T-lymphocytes.

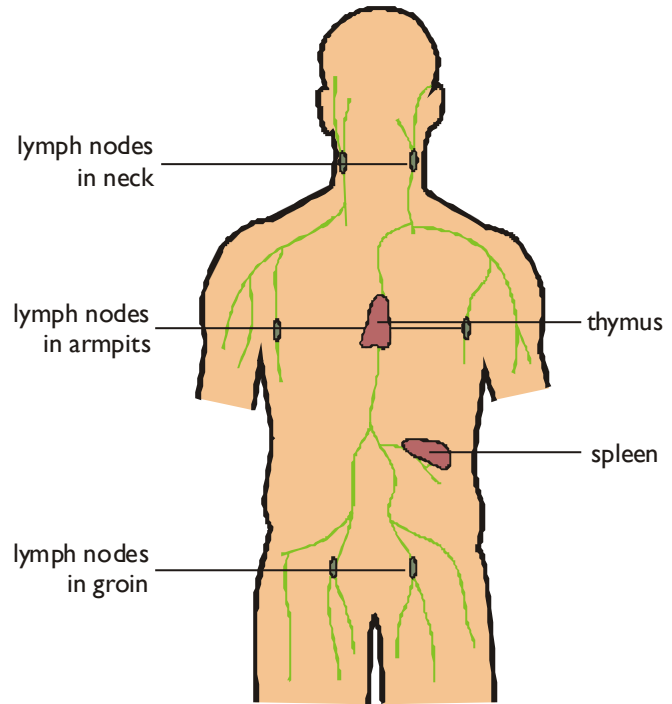

The white blood cells (or leukocytes) are derived from stem cells, which are produced in huge numbers in the bone marrow (the soft centre of large bones). These stem cells differentiate to form dozens of different kinds of leukocytes, which fall into four categories:

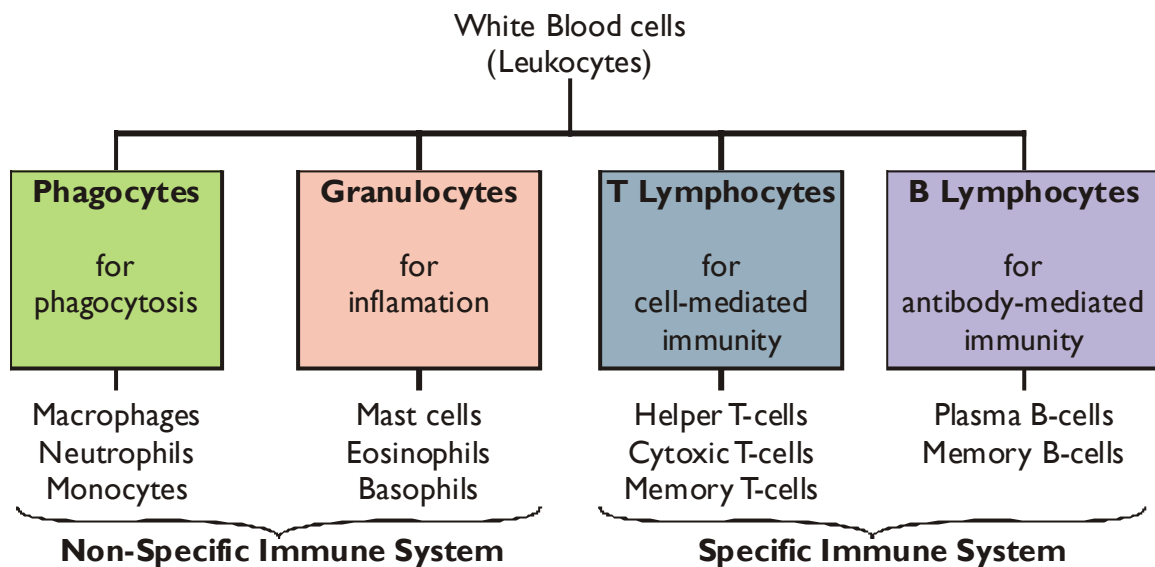

The Three Lines of Defence

Humans have three lines of defence against invading pathogens:

1. Barriers – the skin and associated chemicals stop microbes entering the body
2. The non-specific immune system – phagocytes quickly destroy microbes that pass the first line of defence
3. The specific immune system – lymphocytes kill any microbes that pass the second line of defence, and remain on guard for future attacks.

The First Line of Defence – Barriers

The body has many mechanisms to try to stop microbes entering the body, particularly the bloodstream.

- The skin is a tough, impenetrable barrier (which is why we use it to make leather shoes). The outer layer, the epidermis, is 20-30 cells thick (about as thick as a sheet of paper) and its cells are toughened by the protein keratin.
- Sweat and tears, secreted by glands in the skin, contain lysozyme enzymes, which destroy (lyse) bacteria growing on the surface of the skin by digesting their peptidoglycan cell walls.
- The digestive tract is a potential entry route for pathogens, but it is protected by concentrated acid in the stomach, which denatures microbial enzymes and cell surface proteins, as well as protease enzymes. Saliva also contains lysozymes.
- The respiratory tract is another potential entry route, but it is protected by sticky mucus secreted by glands in the bronchi and bronchioles, which traps microbes and other particles in inhaled air before they can reach the delicate alveoli. Mucus contains lysozymes, and cilia constantly sweep the mucus upwards to the throat, where it is swallowed so that the microbes are killed by the stomach acid.
- The human body is home to billions of bacterial cells called variously the natural microbiota, the normal flora, the commensal flora (because they have a non-harmful or commensal relationship with their host) or even the "friendly bacteria". There are in fact twenty times more bacteria cells in a human than there are human cells! These commensal bacteria colonise the skin, mouth, lower digestive tract, respiratory tract and vagina, and they help prevent infection by out-competing pathogenic microbes for food and space.

The Second Line of Defence – The Non-Specific Immune System

The phagocytes and the granulocytes form the non-specific immune system, a host of quick, non-specific methods of killing microbes that have passed the first line of defence and entered the body. Some of the main methods are:

- Phagocytosis. Phagocytes are large, irregularly-shaped leukocyte cells that remove bacteria, viruses, cellular debris and dust particles. The phagocytes are constantly changing shape, and they flow over microbes, surrounding and ingesting them through the process of phagocytosis to form a phagosome. The phagosome then fuses with lysosomes - small vesicle containing lysozymes, which are released into the phagosome, killing and digesting the microbe. Different phagocyte cells work in different locations: neutrophils circulate in the blood, while macrophages are found in lymph, tissue fluid, lungs and other spaces, where they kill microbes before they enter the blood.
- Complement System. This comprises more than 20 different proteins, which kill microbes by making pores in their cell membranes and can also inhibit viral reproduction inside cells. They are also involved in activating other parts of the immune system.
- Inflammation. This is a localised response to an injury or infection. The granulocyte cells and the affected cells release chemicals, including histamines and prostaglandins, which stimulate: vasodilation to increase the flow of blood to the area (so the area turns red); capillary leakage so that phagocytes and granulocytes can enter the local tissue fluid (so the area swells); sensory neurone impulses (so the area is tender or painful); blood clotting to seal a wound (so a scab is formed). The dead pathogens and phagocytes, together with excess tissue fluid, are released as pus. The chemicals also help to stimulate the specific immune response (see below).
- Fever. This is caused by pyrogen chemicals, which include some of the inflammation chemicals as well as bacterial endotoxins. These stimulate the hypothalamus of the brain to increase the body's temperature from 37°C up to 39°C. This helps the immune system and inhibits growth of some pathogenic bacteria.

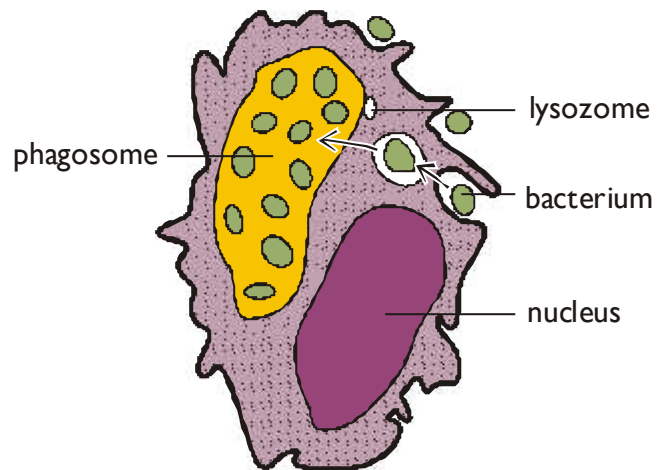

The Third Line of Defence – The Specific Immune System

The lymphocytes form the specific immune system, which is a more complex and sophisticated collection of reactions that not only kill invading pathogens, but also remember the pathogen's features so that it can be killed quickly on subsequent infections. While all animals have a non-specific immune system, only vertebrates have a specific immune system, so it must be a later evolutionary advance. The key difference of the specific immune system is that it is capable of recognising foreign cells as distinct from its own cells, an ability called self/nonself recognition. It does this by making use of antigens.

An antigen is a large molecule (protein, glycoprotein, lipoprotein or polysaccharide) on the outer surface of a cell. All living cells have these antigens as part of their cell membrane or cell wall. The capsid proteins of viruses and even individual protein molecules (such as toxins) can also be classed as antigens. Their purpose is for cell communication, and cells from different individuals have different antigens, while all the cells of the same individual have the same antigens. Antigens are genetically controlled, so close relative have more similar antigens than unrelated individuals. Blood groups are an example of antigens on red blood cells, but all cells have them.

There are two kinds of lymphocyte – B-lymphocytes (or just B-cells) and T-lymphocytes (or just T-cells).

B-cells make antibodies. An antibody (also called an immunoglobulin) is a protein molecule that can bind specifically to an antigen. Antibodies all have a similar structure composed of 4 polypeptide chains (2 heavy chains and 2 light chains) joined together by strong disulphide bonds to form a Y-shaped structure. The stem of the Y is called the constant region because in all immunoglobulins it has the same amino acid sequence, and therefore same structure. The ends of the arms of the Y are called the variable regions of the molecule because different immunoglobulin molecules have different amino acid sequence and therefore different structures. These variable regions are where the antigens bind to form a highly specific antigen-antibody complex, much like an enzyme-substrate complex.

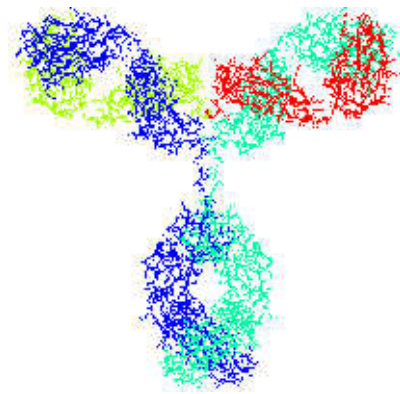
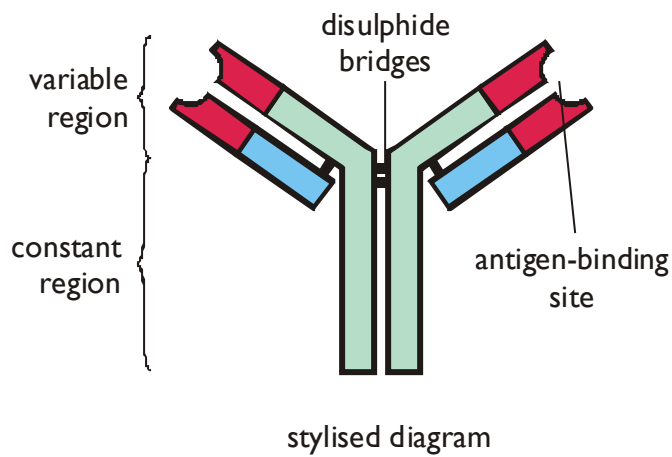

stylised diagram

Rasmol molecular model

Each B-cell has around 10^5 membrane-bound antibody molecules on its surface and can also secrete soluble antibodies into its surroundings. Every human has around 10^8 different types of B cell, each making antibodies with slightly different variable regions. Between them, these antibodies can therefore bind specifically to 10^8 different antigens, so there will be an antibody to match almost every conceivable antigen that might enter the body.

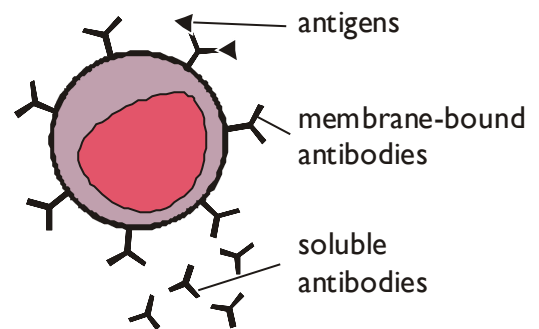

T-cells have receptor molecules on their surfaces which are very similar, but not identical, to antibodies. These receptors also bind specifically to antigens to form anti-gen-receptor complexes. Each T-cell has around 10^5 receptor proteins, and again there are about 10^8 different types of T-cell, each with slightly different receptor molecules, so they can also specifically bind to any conceivable antigen. T-cells do not secrete soluble proteins.

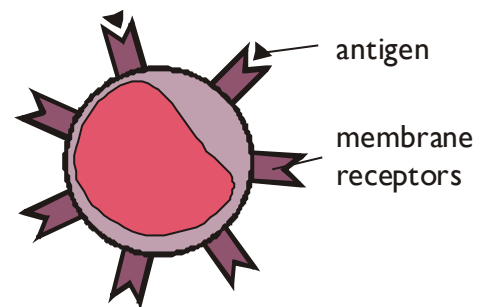

The B and T cells are exposed to so many "self" antigens on every normal cell they come across, that they quickly "learn" to recognise them very early in life. From then on self antigens are ignored, but any non-self antigens are recognised and stimulate an immune response as described below.

The actions of the specific immune system are summarised in this diagram:

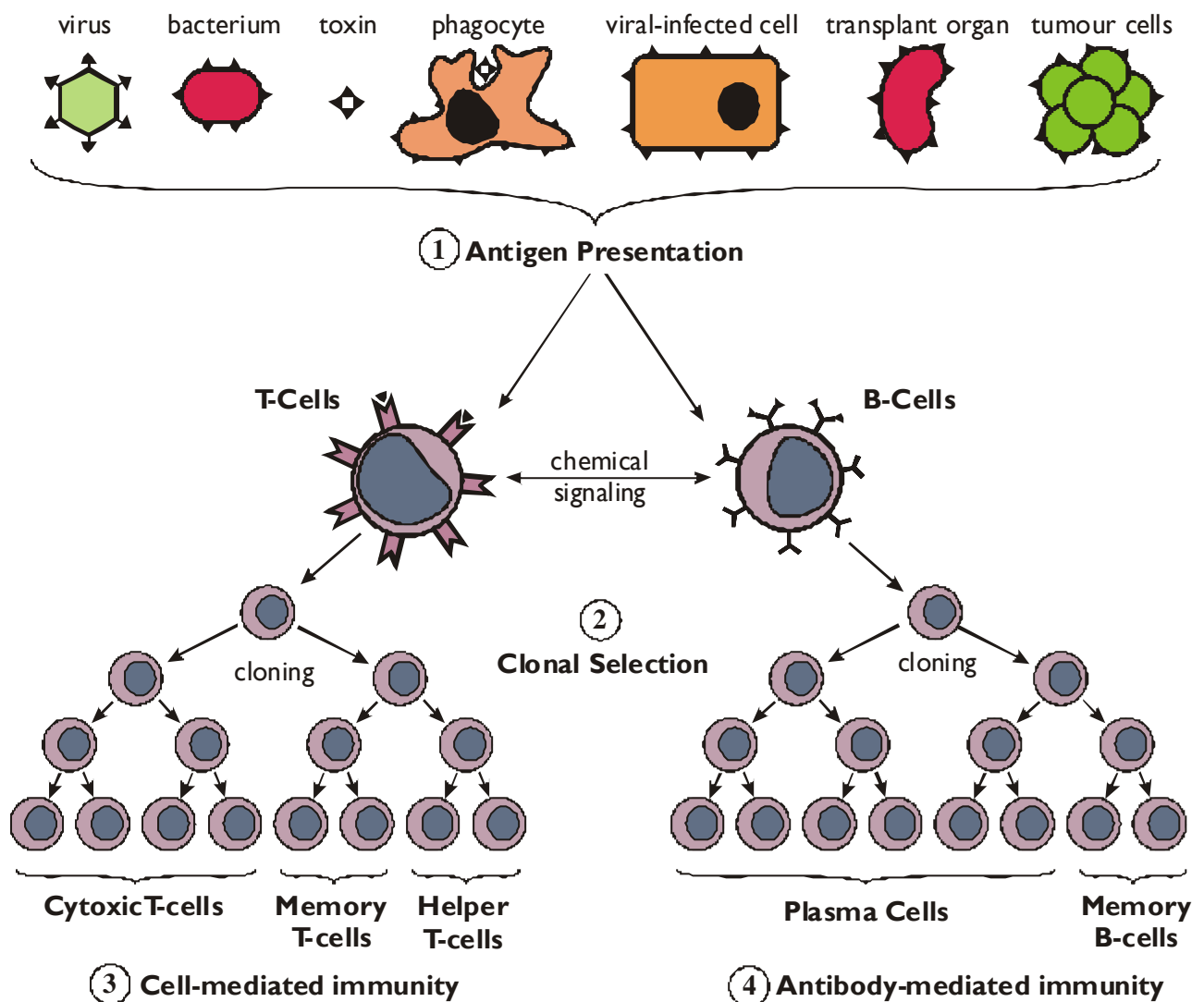

I. Antigen Presentation

Infection is started when cells with non-self antigens enter the blood or tissue fluid. The antigens can be from a variety of sources:

- a virus capsid protein or envelope protein
- on the surface of a bacterial cell
- a toxin released from a bacterium
- on a phagocyte that has ingested a pathogen
- on a cell infected with a virus so that it has viral proteins on its surface
- on the surface of cells of a transplant
- on a cancerous cell

Macrophages are the most important antigen-presenting cells because they are the most numerous. They constantly inspect the surface of every cell they come into contact with in the blood, spleen, lymph nodes, tissue fluid and alveolar spaces. If the antigens are not recognised as self antigens, then the macrophage ingests the antigen and its cell by phagocytosis. Some of the antigens

pass to the surface of the macrophage, which thus becomes an antigen-presenting cell. This amplifies the number of antigens. The macrophage also secretes cytokine chemicals (also called lymphokines or interleukins) to stimulate the lymphocytes.

2. Clonal Selection

At birth we have less than 100 copies of each type of B or T lymphocyte. Whenever a particular antigen enters the body it comes into contact with all the various cells in the blood and lymph, including the lymphocytes. Sooner or later the antigen will encounter a lymphocyte with a matching receptor molecule, to which it can bind tightly. It's a bit like Prince Charming trying to fit the glass slipper (the antigen) onto all the girls in the kingdom (the different lymphocytes) until eventually he finds Cinderella, who is an exact fit. As soon as a match is found, the binding of the antigen to the receptor stimulates the lymphocyte to divide repeatedly by mitosis, making an army of about 10^6 identical cloned B and T lymphocyte cells. This is called clonal selection, because only the selected cell is cloned. This army of clones can now destroy the infecting microbe, as described below.

3. T-Cells and Cell-Mediated Immunity

The T-lymphocytes differentiate into cells with different functions.

- Cytotoxic T-cells (or killer T-cells) bind to antigens on infecting cells and kill the cells by releasing perforin proteins. These insert into the cell membrane of the other cell, where they make a pore, which allows water to diffuse in so that the cell bursts.
- Helper T-cells bind to antigens on infecting cells and secrete chemicals called cytokines. These stimulate all the other white blood cells (phagocytes, granulocytes and B lymphocytes) and speed up the immune response. The AIDS virus HIV destroys these helper T-cells, and the immune system doesn't work nearly as well without them.
- Memory T-cells remain in the blood for many decades after the infection. This means that the same antigen will be identified much more quickly in a subsequent infection, when the memory T-cells will quickly divide to form cytotoxic T-cells and helper T-cells.

4. B-Cells and Antibody-Mediated Immunity (or humoral immunity)

The B-lymphocytes also differentiate into cells with different functions.

- Plasma cells secrete free soluble antibodies. These antibodies are carried around the blood, lymph and tissue fluid binding to any antigens they come into contact with and forming antibody-antigen complexes. A single B-cell can divide to form 10^6 plasma cells, each of which can release 10^3 antibodies each second for 4 days. So during the immune response to an infection there is

an enormous number of antibodies in the body and it is highly likely that every antigen will be targeted by one. The antibodies help to kill cells in various ways:

1. By binding to antigens on viruses and bacteria they prevent the viruses or bacteria attaching to cells and so infecting them.
2. By binding to free toxin proteins they change the shape of the active region so that these proteins can no longer take part in the reactions that caused disease.
3. By linking antigens together. Because each antibody molecule has two antigen-binding sites (one on each arm of the Y), antibodies can stick antigens together into large clumps. This process, called agglutination, immobilises viruses and cells, and precipitates soluble toxins so that they can easily be destroyed by phagocytes or cytotoxic T-cells. Large antigen-antibody complexes also stimulate the various activities of the non-specific immune response, such as phagocytosis, complement production and inflammation.

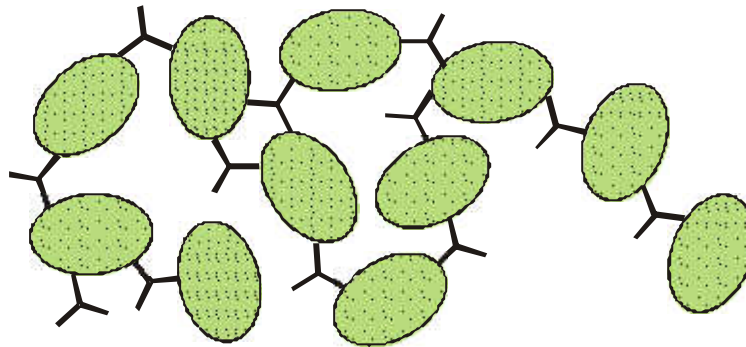

- Memory B cells continue to secrete antibodies in small quantities for many decades, and can multiply rapidly to produce an instant supply of plasma cells if the same pathogen invades again.

Primary and Secondary Immune Responses

The first time a new antigen is encountered there are only a few lymphocyte cells of each kind (<100) for the antigen to encounter, so it can take several days for clonal selection to take place and the clone army to be assembled. Furthermore the clone army tends to be fairly small. This slow and weak response to a first infection is called the primary immune response. It is during this period that the symptoms of the disease are shown, partly due to toxins and cell death due to the pathogen, and partly due to the immune response itself (e.g. fever, inflammation).

After a primary response memory cells (both T and B lymphocytes) remain in the blood. This means that after a subsequent infection by the same antigen the clonal selection stage can be bypassed and the specific immune response is much faster and much greater (i.e. more clone B and T lymphocytes and antibodies are produced). This is called the secondary immune response, and is so fast that the pathogen is destroyed before it reproduces enough to cause disease. In other words the individual is immune to that disease. Note that the non-specific immune response is the same in all infections.

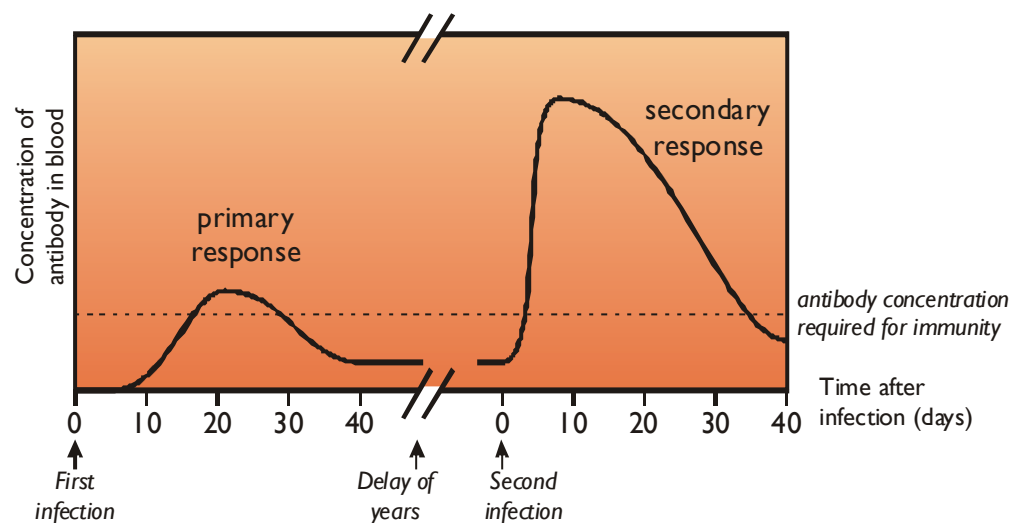

Antigenic Variability

This immunity works well for many diseases, such as chicken pox, measles or mumps. We think of these as childhood diseases because it is common to catch them once as children and never catch them again. However it appears that you can keep on catching some diseases, such as the common cold and the flu. Why does the secondary immune response not work with these diseases? Because these microbes have constantly-changing antigens. This is referred to as antigenic variability, and it is caused by mistakes in DNA or RNA replication (mutations) due to poor polymerase enzymes. The result is that each infection causes a new primary response, with all the trappings of the accompanying disease. With some diseases the pathogen is so active and the toxins so effective that the first infection causes a disease that is fatal (e.g. cholera, smallpox, diphtheria, AIDS).

Immunisation

We have been able to make use of the immune system's memory to artificially make people immune to certain diseases even without ever having caught them. The trick is to inject with an antigen that will promote the primary immune response, but has been modified so that it is non-virulent (or non-pathogenic), i.e. will not cause the disease. The immune system is thus fooled into making memory cells so that if the person is ever infected with the real virulent pathogen, the more powerful secondary immune response is triggered and the pathogen is killed before it can cause the disease. This technique is called vaccination and is commonly used to provide artificial immunity to a number of potentially-fatal diseases. In the UK children are commonly vaccinated against diphtheria, tetanus, whooping cough, polio, measles, mumps, rubella and TB.

Passive Immunity

Injecting antigens to promote an immune response is called active immunity, but it is also possible to inject antibodies against certain pathogens into the blood. This is called passive immunity and is used when someone has already been infected (or is likely to become infected) with a pathogen. The antibodies in it assist the body's normal immune response and help it deal with serious diseases. Antibodies are either prepared from the blood serum of an infected human (or rarely animal), called an antiserum, or are made by genetic engineering. Passive immunisation is not very common, but can be used for rabies, tetanus, measles and hepatitis B, and is being tried to combat AIDS.

Passive immunity also occurs naturally when a mother passes antibodies to her child. Antibodies can pass across the placenta to the foetus and are also found in colostrum, the milk produced in the first few days after birth. Since the baby's digestive system does not function at this stage, the immunoglobulin proteins can be absorbed intact. This passive immunity helps the new-born baby survive in a world full of pathogens, and is one reason why breast feeding is so important.

The different kinds of active and passive immunity are summarised in the table.

	Active Immunity (antigens received)	Passive Immunity (antibodies received)
Natural	Achieved through the primary immune response following an infection	Achieved through the passing of antibodies from mother to child through the placenta and milk.
Artificial	Achieved through injection of modified antigens (vaccination).	Achieved through injection of antibodies (antiserum).

Monoclonal Antibodies

Scientists quickly realised that the remarkable specific binding property of antibody proteins *in vivo* would make them very useful tools in medicine and research *in vitro*. [*In vivo* means “in life”, i.e. in a living organism; and *in vitro* means “in glass”, i.e. in a test tube.] For example antigens could be used as a “magic bullet” to target drugs at one specific cell type in the body, or antibodies could be used to detect the presence of specific proteins in very low concentrations. So in 1975 Kohler and Milstein found a way to make pure monoclonal antibody proteins in the lab. This is their technique:

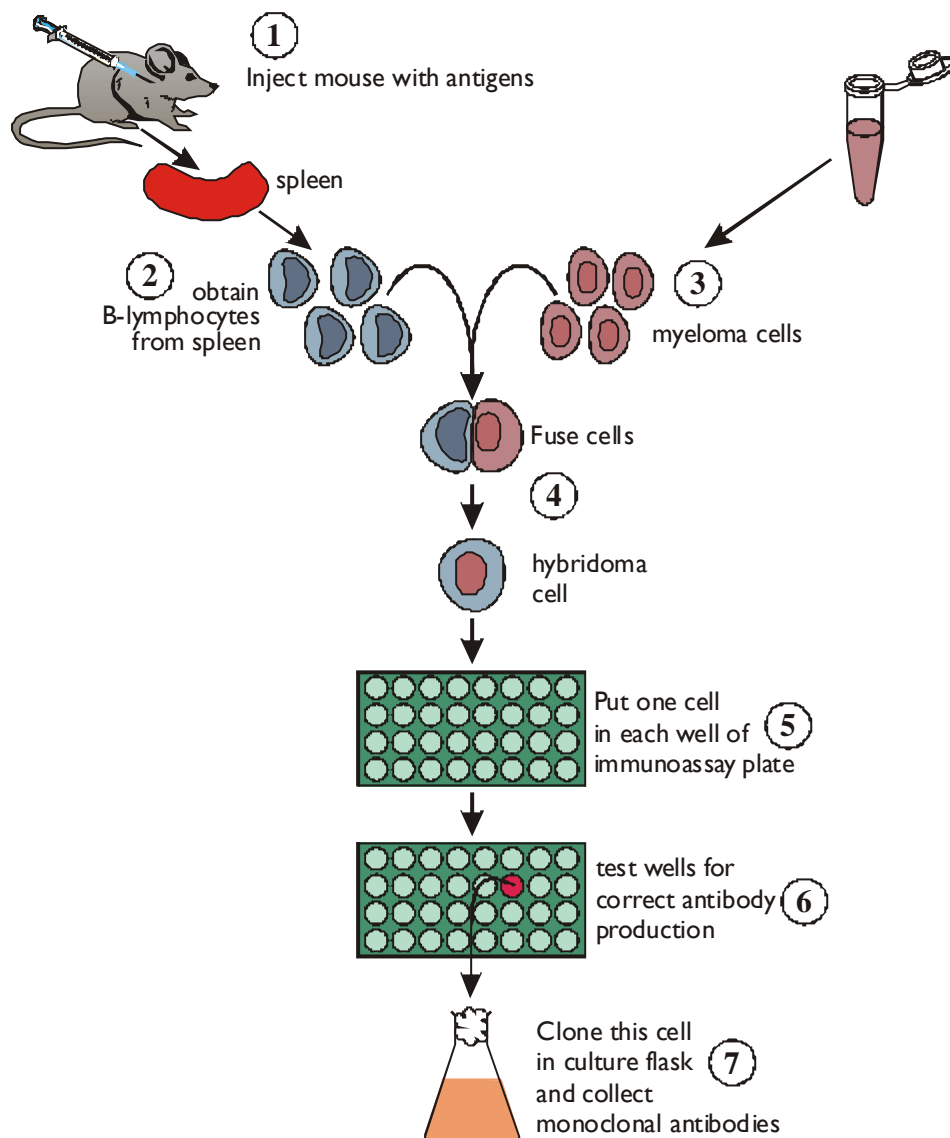

1. Inject a mouse with the antigen proteins that you want antibodies for. These antigens could be from a human cancer cell or a particular protein. The mouse will show a primary immune response and make a clone army of B lymphocytes with antibodies specific for that antigen.
2. After a few days, kill the mouse and extract B lymphocyte cells from its spleen. Although these B cells will make antibodies, there are two problems: B lymphocyte cells won't grow *in vitro*; and the spleen extract contains a mixture of thousands of different B cells, each making their own specific antibodies.

3. The first problem is solved by using “immortal” myeloma cells – cancerous mouse cells that will divide indefinitely *in vitro*.
4. The B lymphocytes from the spleen extract are mixed with myeloma cells in a Petri dish and fused using a detergent. The fused, or hybrid, cells are called hybridoma cells. They have the properties of both cell types: they can grow *in vitro* and they can make antibodies.
5. The second problem is solved by diluting the cells into hundreds of wells in an immunoassay plate, so that there is just one cell per well. The cells multiply in their wells and secrete antibodies – a different antibody in each well.
6. Each well is then screened for production of the antibody required.
7. The B cells from that well are then grown in a culture flask, where they multiply by mitosis, making millions of identical cloned cells, each secreting identical antibodies – monoclonal antibodies.

Monoclonal antibodies have many uses, e.g.

- Antibodies can be made to an antigen found on a cancer cell, and a toxic agent is bound to the antibody (e.g. a radioactive substance). The antibody/toxin complex can then be injected into a cancer patient and the antibody will ensure that the agent is carried only to cancer cells and nowhere else.
- Antibodies to the protein hormone hCG, produced in pregnancy, are bound to a test strip and used to detect the presence of hCG in urine in a pregnancy test strip.
- Antibodies can be used directly in passive immunity to help the body's normal immune response to a serious infection.