



The Biological Importance of Water

Water (H_2O) is the most abundant molecule in cells, whole organisms and on earth. This is a consequence of the unique physical and chemical properties of water. This Factsheet will briefly explain the significance of these physical and chemical properties, then discuss the primary roles of water in animals and plants.

Water is a polar molecule i.e. it has both positively charged and negatively charged areas. Water is made up of two positively charged hydrogen atoms and one negatively charged oxygen atom (Fig 1).

Fig 1. The polarity of water molecules

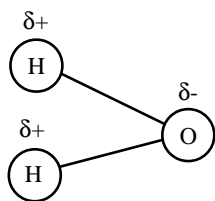

As a result of this polarity (the uneven distribution of charges), adjacent water molecules are attracted to and become bonded to each other. The slight positive charge of a hydrogen atom of one molecule is attracted to the slight negative charge of an adjacent oxygen atom. A hydrogen bond forms between them (Fig 2).

Fig 2. Hydrogen bond between two water molecules

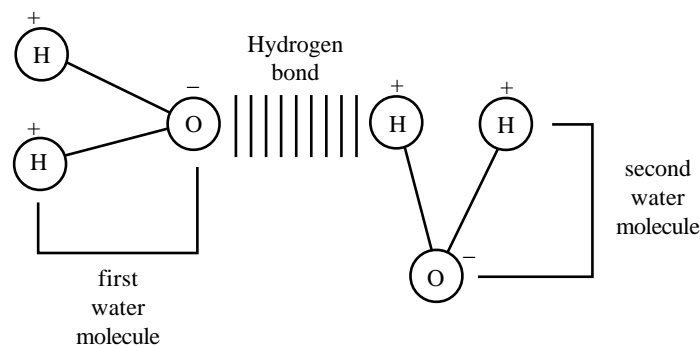

The individual hydrogen bonds are weak but collectively they make water very stable i.e. it remains a liquid over a huge range of temperatures (0-100°C). This is vital in living organisms.

1. Solvent properties

Polar molecules and ionic compounds such as sodium chloride dissociate in water. Sodium chloride ($NaCl$ or 'salt') is made up of a positively charged sodium ion (Na^+) and a negatively charged chloride ion (Cl^-). As a result of the opposite charges, the two ions are attracted to each other and a bond forms between them. When the salt is added to water the sodium and chloride ions split apart (dissociate). They do this because the force of attraction between the negatively charged part of the water molecule and the positively charged sodium ion is greater than the forces of attraction between the Na^+ and the Cl^- ion. The negative part of the water molecule attracts and pulls away the positive part of the salt molecule. Similarly, the positive part of the water molecule attracts and pulls away the negatively charged chloride ion. Both the Na^+ and Cl^- become surrounded by water molecules; in other words they become hydrated. Polar substances which dissociate in water in this way are said to be **hydrophilic**.

Some large molecules have strong **intramolecular** forces and do not dissociate or dissolve in water. However, some of these molecules do have charged areas on their surface, which attract a layer of water around the molecules.

This layer of water means that the molecules remain dispersed, which prevents them joining together and settling out. This is known as a colloid or colloidal suspension; the water molecules which surround the large molecule are weakly bound to the molecule and cannot move away from its surface. This is important because such molecules provide an osmotic effect, helping to draw water into the blood vessels, for example.

The fact that water is an extremely effective solvent is of great biological importance. All of the substances which are essential for the functioning of cells and whole organisms (glucose, amino acids, fats, vitamins, respiratory gases etc.) are transported around in solution. Similarly, all metabolic reactions, catalysed by enzymes, occur in solution.

To summarise, the charged nature of the water molecule (i.e. its polarity), gives it stability and allows it to act as a solvent - both essential properties to living organisms.

2. Thermal properties

The hydrogen bonding between water molecules is also responsible for the unique thermal properties of water. Water has a high specific heat capacity i.e. it takes a lot of energy to raise the temperature of water or conversely, a lot of energy can be lost before the temperature of water starts to fall. This is crucial for living organisms which need to maintain particular temperatures in order to optimise enzyme activity. The high water content of cells and tissues helps them to maintain a constant temperature. In this way water acts as a **temperature buffer**.

Hydrogen bonding is also responsible for the fact that ice is less dense than water and therefore floats. As the temperature of water decreases, the kinetic energy of the individual molecules decreases and the molecules slow down. This allows each molecule to form the maximum number of hydrogen bonds with other water molecules (Fig 3).

Fig 3. The stable structure formed by hydrogen bonds in ice

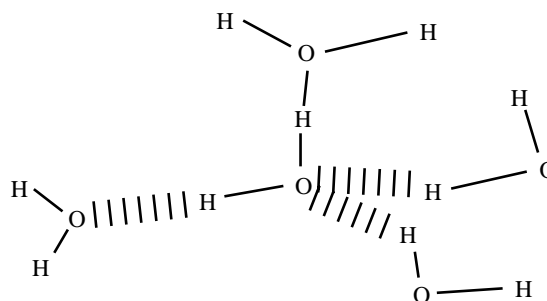

To achieve this structure, the water molecules spread out i.e. expand to accommodate more bond formation. Because ice floats i.e. water freezes from the top down, many organisms are able to survive below the surface of the ice.

Conversely, when water molecules do escape from the water surface during evaporation, a lot of energy is released with them. As a result, evaporation (e.g. sweating or panting) is an efficient cooling mechanism, allowing living organisms to maintain a constant body temperature. The properties and functions of water in living systems are summarised overleaf.

FUNCTION	EXAMPLES/EXPLANATIONS
Transport	<p>Uptake of minerals by plants from soil across root hairs occurs in solution. Transpiration stream and water-based movement of sugars and amino acids, hormones etc. in phloem occurs in solution.</p> <p>All transport fluids used in animals (e.g. cytoplasm, blood, plasma and tissue fluid) are water-based.</p> <p>Many essential metabolites dissolve completely e.g. glucose, amino acids, vitamins and minerals.</p> <p>Larger molecules e.g. proteins are transported as colloids.</p> <p>Transpiration stream is held together by cohesion (water molecules hydrogen bond to other water molecules) and adhesion (water molecules bind to side of xylem vessel). Such forces also give rise to capillarity in tubes of very small diameter. Low viscosity of water enables it to flow easily through tubes e.g. xylem vessels.</p>
Chemical reactions (metabolism)	<p>Combination of thermal stability and excellent solvent properties makes water an ideal environment for chemical reactions. All enzyme reactions of photosynthesis, respiration, excretion etc. occur in solution.</p> <p>Water also acts as a reactant for example, in:</p> <ol style="list-style-type: none"> 1. Light dependent stage of photosynthesis when photolysis splits water to release electrons which move to photosystem II (PSII) and then through electron carriers in non-cyclic photophosphorylation pathway (NCP). 2. Hydrolytic reactions (e.g. digestive enzymes).
Temperature control	<p>High specific heat capacity allows water to act as a buffer; essential in endothermic organisms that need to maintain a constant body temperature in order to optimise enzyme activity and thereby regulate metabolism.</p> <p>High incidence of hydrogen bonding also makes it difficult for water molecules to evaporate. When they do so, much energy is released and this is involved in cooling mechanisms.</p> <p>Water remains a liquid over a huge temperature range - essential for metabolism and useful for aquatic organisms which avoid freezing.</p>
Support	<p>In plant cells water confers turgidity. This is essential for example, in:</p> <ol style="list-style-type: none"> 1. Maintaining maximum leaf surface area, hence light absorption, hence photosynthesis. 2. Maintaining aerial parts of the plant to maximise seed dispersal or pollination. Loss of water in very hot conditions may lead to leaves wilting. This decreases their surface area, hence light absorption, temperature and water loss. <p>In animals, water-filled tissues also contribute to skeletal support. In organisms which possess a hydrostatic skeleton (e.g. annelids), water is the major component of the fluid in the coelom against which muscles can act.</p> <p>For aquatic organisms, water provides support through buoyancy.</p>
Movement	<p>Nastic movements, i.e. those which do not involve growth in a particular direction as a response to a directional stimulus, depend upon the osmotic inflow of water into tissues, e.g. the opening and closing of flowers or 'snapping' of the carnivorous Venus Fly Trap.</p> <p>Organisms such as earthworms and leeches use their hydrostatic skeletons to move around. Longitudinal and circular muscles are able to contract against the incompressible watery fluid of the coelom.</p>
Reproduction	<p>Organisms which employ sexual reproduction use water to bring the male and female gametes together in the process of fertilisation.</p> <p>In mammals the foetus develops in a water filled sac which provides physical and thermal stability.</p> <p>Bryophytes release antherozoids in moist conditions which use flagella to swim to oospheres by chemotaxis.</p>

Acknowledgements;

This Factsheet was researched and written by Catherine Brown.

Curriculum Press, Unit 305B, The Big Peg, 120 Vyse Street, Birmingham. B18 6NF

Biopress Factsheets may be copied free of charge by teaching staff or students, provided that their school is a registered subscriber.

No part of these Factsheets may be reproduced, stored in a retrieval system, or transmitted, in any other form or by any other means, without the prior permission of the publisher. ISSN 1351-5136